



Manual and Parts List

Singer 321C

**Copyright 2016 © Supra Enterprises Corp.
Wholesale And Retail Sewing Machines Miami FL**

Address: 7630NW 25Th St. Unit 3&4 Miami, FL 33122
Phone numbers: Ph: (305)-406-1067 Fax: (305)-406-1068

Instruction Manual and Parts List

High Speed Overlock Machine

321C

131M-04	243M-24 /TF
132M-015	244M-24
133M-04 /TF	251M-35
134M-04	251M-55
241M-24 / 25	251H-56



SINGER®

Contents

1	Safety Instructions	1
1.1	Important Safety Instructions	1
1.2	Safe Operation	2
2	Product Description and Machine Specification	3
2.1	Product Description	3
2.2	Machine Specification	4
2.3	Motor, Motor Pulley and Belt	4
3	Mounting and Adjustment Instructions	5
3.1	Table Cut-Out Diagram	5
3.2	Machine Installation	6
3.3	Lubrication and Oil Drainage	8
3.4	Needle Attachment (or Replacement)	9
3.5	Machine Threading	9
3.6	Thread Tension Adjustment	10
3.6.1	Tension Nut Adjustment	10
3.6.2	Needle Thread Control	10
3.6.3	Looper Thread Control	11
3.6.4	Chain Looper Thread Cam Control	11
3.7	Adjusting the Differential Feed Rate	12
3.8	Stitch Length Adjustment	12
3.9	Parts Relation and Timing	13
3.9.1	Needle and Needle Plate	13
3.9.2	Upper Looper (Spreader) and Needle	14
3.9.3	Lower Looper and Needle	14
3.9.4	Upper and Lower Loopers	15
3.9.5	Needle and Needle Guard	15
3.9.6	Chain Looper and Needle	15
4	Maintenance	16
4.1	Machine Head Cleaning	16
4.2	Oil Change and Filter Cleaning	16
4.3	Safety Inspection	16
5	Troubleshooting	17

Contents

6	Parts List	19
6.1	Frame Components	20
6.2	Cloth Plate Components	22
6.3	Cover Components	24
6.4	Main Shaft Components	26
6.5	Needle Bar Components	28
6.6	Thread Guide Components	30
6.7	Upper Looper Components	32
6.8	Lower Looper Components	34
6.9	Front Looper Components	35
6.10	Cam Components	36
6.11	Differential Feed Components	38
6.12	Feed Dog Components	40
6.13	Trimming Components	42
6.14	Presser Foot Components	44
6.15	Lubrication Components	46
6.16	Feed Snap Components	48
6.17	Thread Spool Components	50
6.18	Plate Row Material Components	52
6.19	Accessories	53
7	Gauge Parts List	54

1.1

Important Safety Instructions

Important

When using the machine, basic safety procedures must be followed.

Read with attention all instructions before using the machine.

When using it, understand that all basic safety instructions are not limited to the following items.

Read all instructions, take care of this manual, and use it as reference when necessary.

- Before running the machine, make sure all relevant safety specifications are adequate to specifications and technical standards in your country.
- The machine should not be run without its safety devices.
- The machine should only be operated by properly trained personnel.
- For your safety, goggles must be used while running the machine.
- Turn off or unplug the machine in the following situations:
 - Passing the thread by the needle or replacing the bobbin or looper.
 - Replacing the needle, presser foot, throat plate, feed dog and sliding plate.
 - When the machine is in maintenance.
 - When the operator is not running the machine.
- In case of lubricant oil contact with the eyes or skin, wash the surface with plenty of icy water. In case of ingestion, seek medical help immediately.
- Repair, fitting or maintenance should only be performed by properly trained personnel.
- Maintenance and repair on electric equipment should only be made by qualified personnel. If any electric device is damaged, the machine should be immediately stopped.
- Before starting the machine in full running, a test must be conducted to assure that machine and operator are able to perform the task.
- The machine should not be placed next to a sound source as an ultrasonic welding machine and other equipment.
- The machine should only be run with the proper electric cable and connectors, and also the adequate grounding.
- The machine should only be used to sew materials as indicated in its instructions manual, and indications of use should be followed.

Singer will not be held responsible for any damage caused by unauthorized changes in the product.

1.2

Safe Operation

- ⚠️ • To avoid the risk of electric shock, do not open the motor wiring box and do not touch the components assembled inside the wiring box.
- To avoid injuries do not run the machine without the belt cover or in case any other safety device is removed.
- To avoid possible injuries keep fingers, head, and clothes far from wheel, belt and motor when the machine is running. Nothing should be placed near those parts.
- To avoid injuries never put your fingers next to the loopers when the machine is running.
- The shuttle whirls at high speed while the machine is running. To avoid hand injuries, keep them away from the shuttle while the machine is running. Turn off the machine to replace the bobbin.
- To avoid possible injuries be careful when putting down or lifting the machine head.
- To avoid accidents in case of a sudden start of the machine always turn it off when laying it down, or remove the belt cover and the belt.
- If your machine is equipped with a servomotor, it does not make noises while being driven. To avoid a possible accident caused by an unexpected start, be sure the machine is turned off.
- To avoid electric, do not run the machine without proper grounding.
- ⚠️ • To minimize the risk of accidents or damages in electric components caused by electric discharge turn the machine off before unplugging it.
- Clean the machine periodically.

2

Product Description and Machine Specification

2.1 Product Description

High Speed Overlock Machine

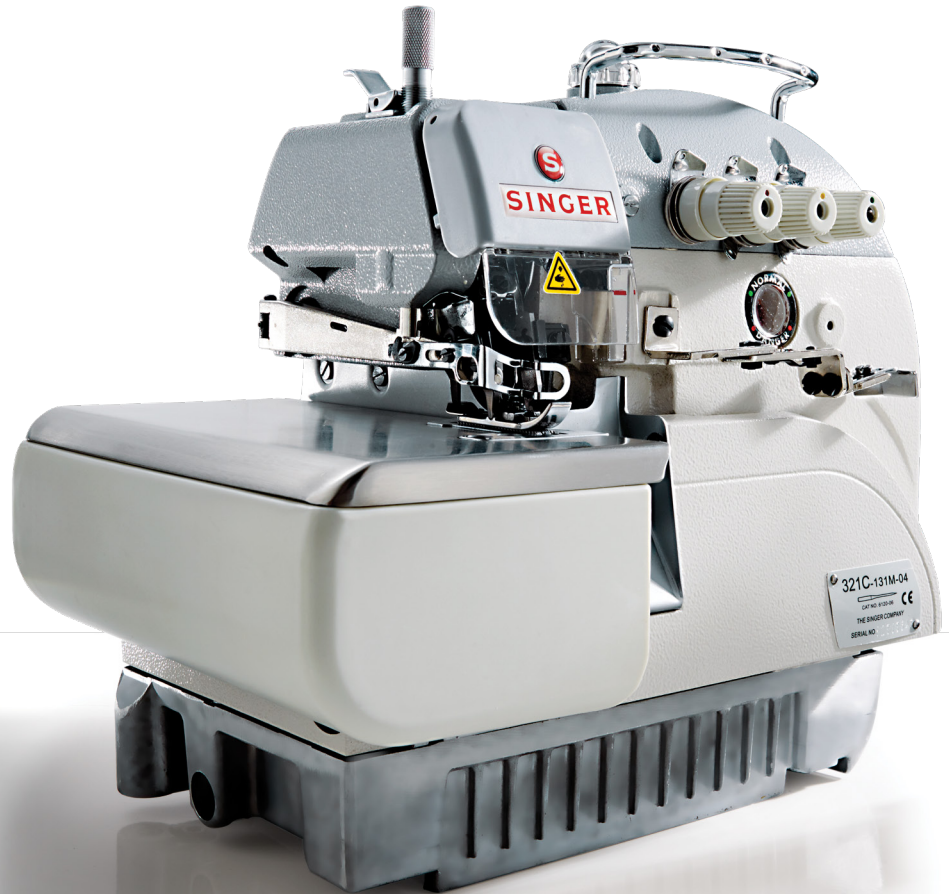

From the library of: Diamond Needle Corp

2.2

Machine Specification

Model 321C	Needle	Thread	Gauge [mm]	Stitch width [mm]	Stitch Length [mm]	Differential	Presser Height [mm]	Needle Singer Type	Speed [spm]	Usage
131M-04	1	3	-	4.0	3.6	0.7~2.0	5.5	6120-06 75/11	6,000	Three-thread overlock machine
132M-015				1.5				6120-06 65/9	6,000	Three-thread handkerchief edging (rolled hem) overlock machine
133M-04 /TF				4.0				6120-06 75/11	5,500	Three-thread elastic attaching overlock machine
134M-04				4.0				6120-06 75/11	6,000	Three-thread back latch overlock machine
241M-24	2	4	2	4.0	3.6	0.7~2.0	6.0	6120-06 75/11	6,000	Four-thread overlock machine
241M-25				5.0				6120-06 75/11	6,000	Four-thread overlock machine
243M-24 /TF				4.0				6120-06 75/11	5,500	Four-thread elastic attaching overlock machine
244M-24				4.0				6120-06 75/11	6,000	Four-thread back latch overlock machine
251M-35	3	5	3.0	5.0	3.6	0.7~2.0	6.0	6120-06 90/14	5,500	Five-thread overlock machine
251M-55			5.0	5.0				6120-06 90/14	5,500	Five-thread overlock machine
251H-56			5.0	6.0				5.0	6120-06 130/21	5,500

From the library of: Diamond Needle Corp

2.3

Motor, Motor Pulley and Belt

- Clutch motor 1/2 HP (400W) high speed (2 poles)
- Belt type M

Maximum Machine Speed [spm]	Motor Pulley Diameter [mm]	
	60 Hz	50 Hz
4,500	70	90
4,750	75	95
5,000	80	100
5,250	85	105
5,500	90	110
6,000	95	115

3

Mounting and Adjustment Instructions

3.1

Table Cut-Out Diagram

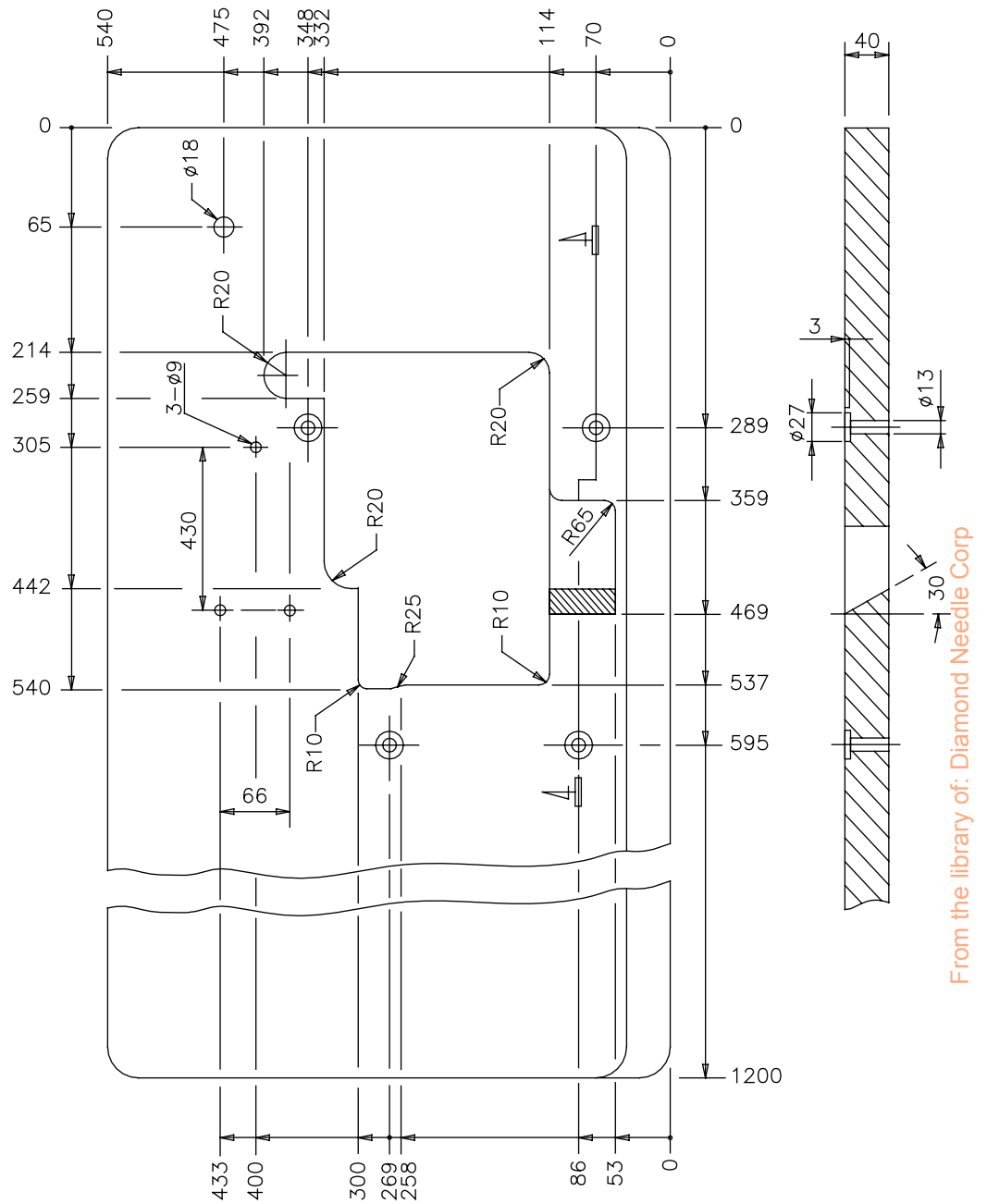

Figure 1

3.2

Machine Installation

Install the machine support components and the residues cam as indicated on figure 2. In case of semi-inserted assembly the distance from

the needle bed surface to the table top is 100mm. For inserted assembly the distance is about 5.0mm.

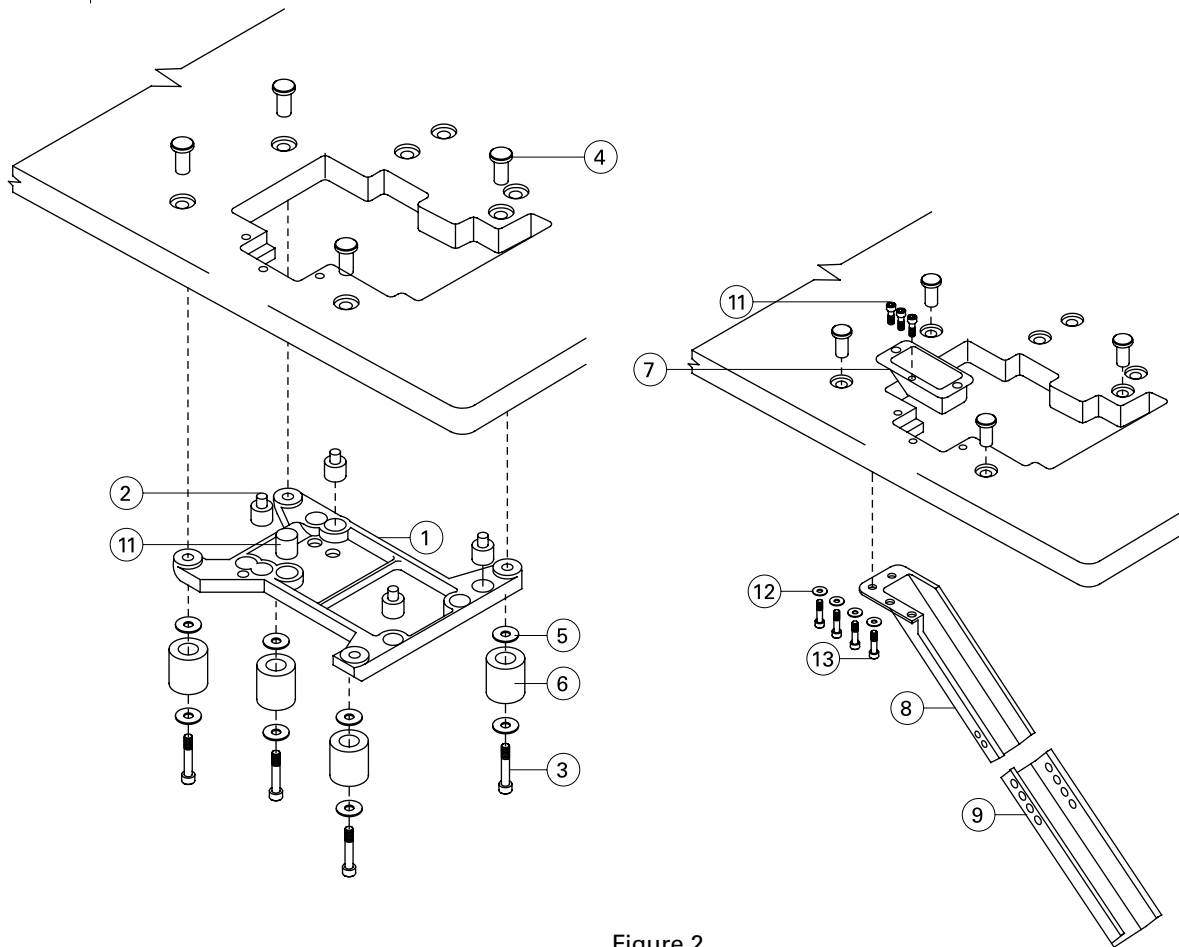

Figure 2

From the library of: Diamond Needle Corp

3.2 Machine Installation

Set the machine head on the support base.

Connect the machine wheel to the motor with the belt.

Adjust the belt tension so that there is a gap of about 20 mm when the center of belt is pressured.

Set the belt cover according to figure 4.

Install the friction motor pedal at the right side and the pedal of the presser lifter at the left side.

Be sure the motor is clockwise directed, referred to figure 3.

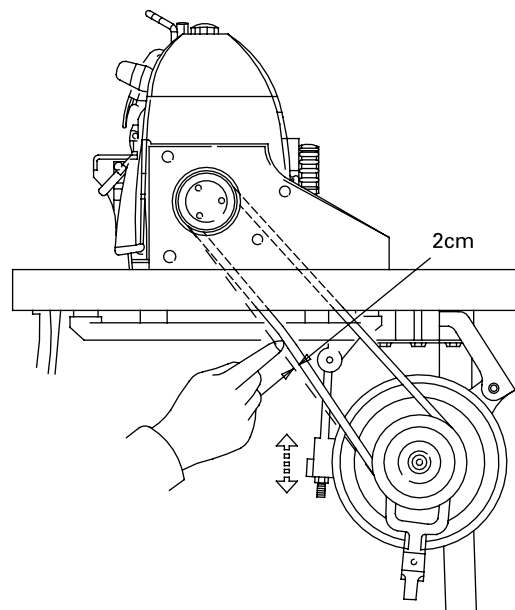

Figure 3

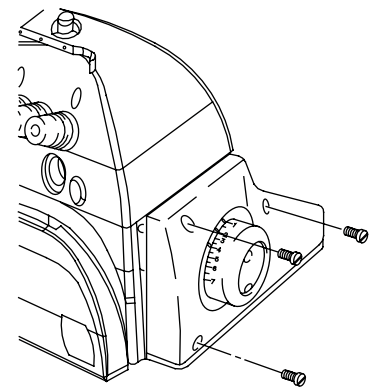

Figure 4

3.3

Lubrication and Oil Drainage

Important

As this is a high speed machine, **DO NOT** run the machine before oiling and assuring the direction of motor rotation.

Remove the oil flow sight window 'A' and fill with the lubricant oil (Singer Oil), until the indicator of the oil level is between the two lines of the oil level sight window 'B'. After that, put back the oil flow window 'A' and squeeze it.

When using the machine for the first time, or a machine that has not been used for some time, oil the needle bar top, the guides and loopers before running it.

A new machine should be run at 80% maximum speed on the first four weeks. After this initial cycle,

replace the oil and from then on the machine can be used at maximum speed.

To preserve the machine, change the oil after four weeks of use. After that the oil must be changed every four months. To change the oil simply remove the screw 'C' indicated on figure 6. After draining the oil, replace the screw and complete the machine with new oil.

This machine has an oil filter (figure 6) that must be cleaned every month or changed as needed.

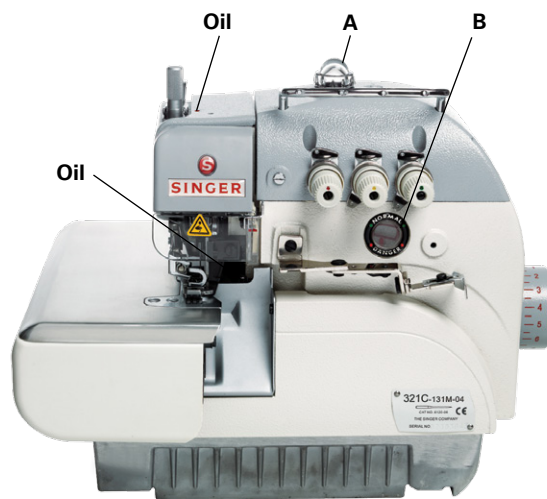

Figure 5

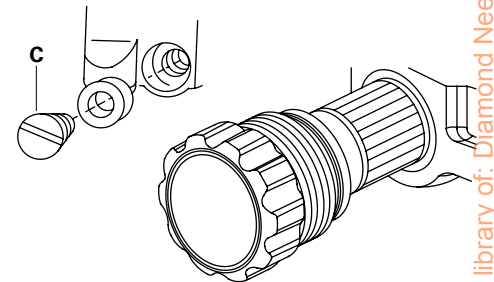

Figure 6

3.4

Needle Attachment (or Replacement)

Use needle Singer 6120-06.

Release screw '1' as indicated on figure 7 and put (or withdraw the old needle).

Insert the needle with the slot turned to the back side and push it up until the bar end. Tighten screw '1':

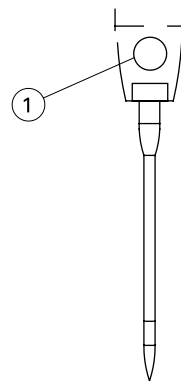

Figure 7

3.5

Machine Threading

Important

Refer to the sewing type you need for correct threading. Any incorrect threading may cause thread brake, uneven stitches or skip stitches.

For five thread machine

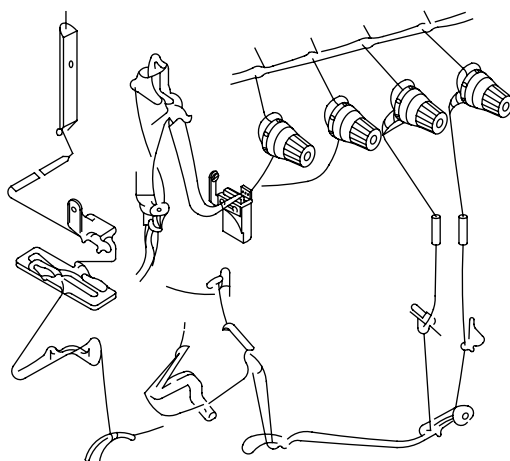

Figure 8

For three / four thread machine

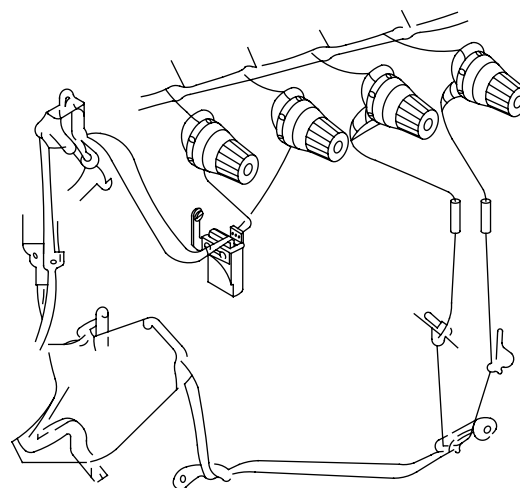

Figure 9

From the library of: Diamond Needle Corp

3.6

Thread Tension Adjustment

3.6.1

Tension Nut Adjustment

Important

The thread tension should be adjusted according to the type and thickness of cloth, thread, sewing width, stitch length and others. Therefore, the pressure on the Tension Buttons or Thread Guides should be individually adjusted for each case.

The following adjustments are related to figure 10.

Tension Nut 1: controls the needle thread or the left thread in case of two needles.

Tension Nut 2: controls the thread in the right needle.

Tension Nut 3: controls the thread in the right looper

Tension Nut 4: controls the thread in the left looper

Tension Nut 5: controls the thread of the safety stitch.

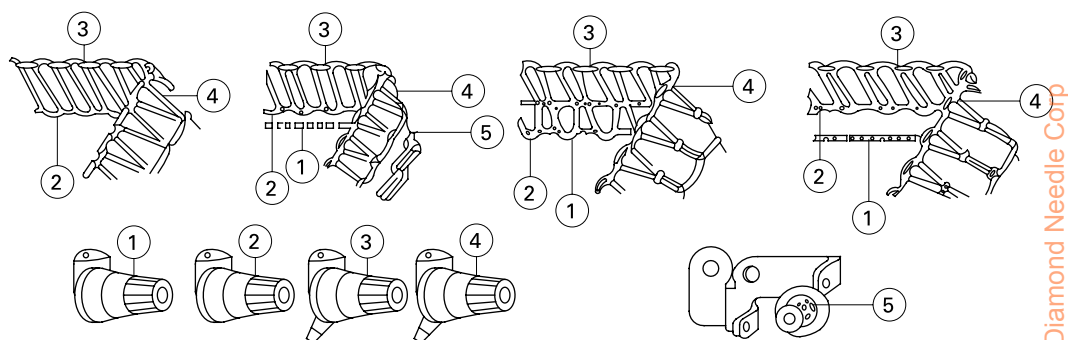

Figure 10

From the library of: Diamond Needle Corp

3.6.2

Needle Thread Control

Note

The signal (+) increases the tension in the thread. The signal (-) reduces the tension of the thread.

For all types of stitch 504, 512 or 514, move down the guides '1' and '2'.

For the types of stitch 503 and 505, move the guides '1' and '2' to the highest point.

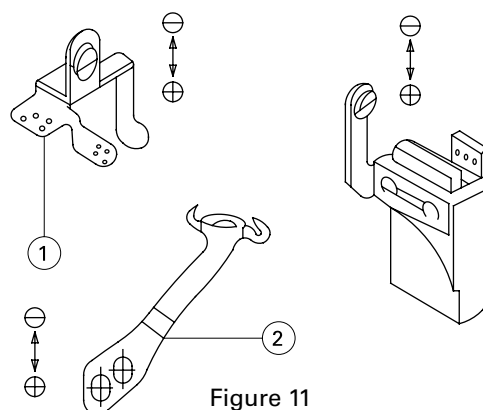

Figure 11

3.6.3

Looper Thread Control

Note

The signal (+) means more thread and (-) means less thread.

For the type of stitch 512, when Adjust guide '1' and '2' as follows the looper on the right is at the left far end, adjust '1' and '2' in level with the dotted mark, as on figure 12.

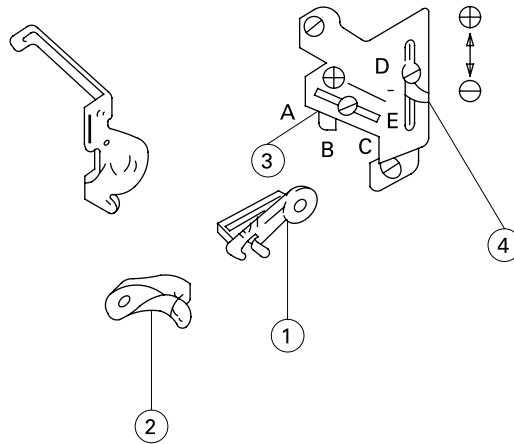

Figure 12

For the type of stitch 503 and 505, move the guides to the lowest point and adjust '1' and '2' in level with the continuous line.

Adjust guide '3' as follows:

- Position 'A': for stretchy thread
- Position 'B': for seaming and blind stitch hemming
- Position 'C': stitch type 512

Adjust guide '4' as follows:

- Position 'D': for stretchy thread
- Position 'E': for seaming and blind stitch hemming.

3.6.4

Chain Looper Thread Cam Control

When the needle is on high position, mark 'A' must be aligned with the thread guide bracket '1', as shown on figure 13.

Release screw '2' and the thread cam '3'. Turn it clockwise for quick release of thread through the cam.

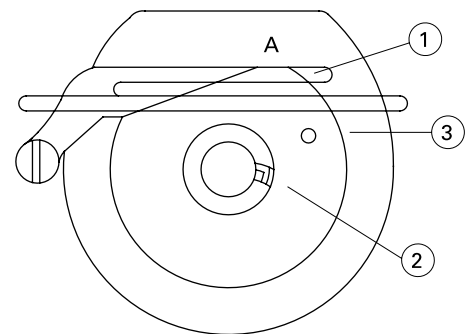

Figure 13

3.7

Adjusting the Differential Feed Rate

Note

When the surface of level '3' adjustment is on scale 2, the differential adjustment is 1 : 1, and if it is on the scale, its proportion may be adjusted up to 1 : 0.7.

Adjustment of the differential is the dragging proportion between the main feed dog and differential feed dog. When the movement of main feed dog is less than that of the differential feed dog, the cloth will be frilled during sewing. Otherwise, the cloth will be stretched.

Adjust Differential	Scala				
	1	2	3	4	5
1 : 3	-	1 : 0.7	1 : 0.9	1 : 1.1	1 : 1.3
1 : 2	1 : 0.7	1 : 1.0	1 : 1.4	1 : 1.7	1 : 2.0
1 : 3	1 : 1.0	1 : 1.5	1 : 2.0	1 : 2.5	1 : 3.0
1 : 4	1 : 1.1	1 : 1.6	1 : 2.3	1 : 2.8	1 : 3.3

Release nut '1' on figure 14, and turn screw '2' clockwise to stretching the cloth or counter clockwise to shrink it. Retightend the nut '1'.

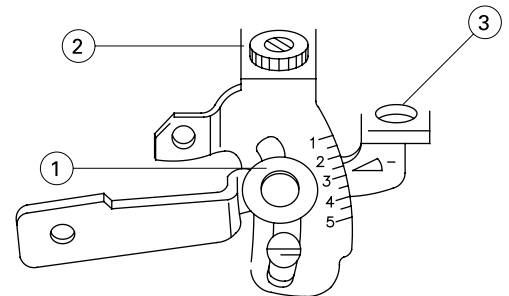

Figure 14

3.8

Stitch Length Adjustment

Important

The stitch length adjustment is made according to the sewing fabric, differential feed ratio and other factors.

Press button to the end and keep it pressed as shown on figure 15.

Turn the wheel until we have the desired stitch length. It is shown on the wheel scale.

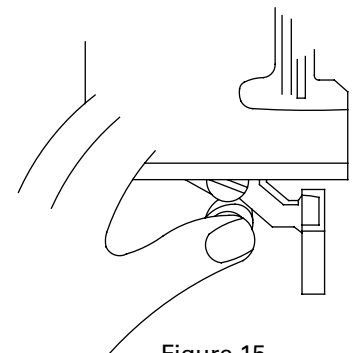

Figure 15

Dragging Proportion	Type of Machine	Wheel Scale						
		1	2	3	4	5	6	7
1 : 2.0	Seaming	1.0	1.5	2.0	2.5	3.0	3.5	3.8
1 : 3.0	Shirring	0.7	1.0	1.4	1.7	2.0	2.3	2.5
1 : 1.3	Serging	1.6	2.3	3.1	3.9	4.7	5.4	5.9
1 : 4.0	Special	0.6	0.9	1.2	1.5	1.8	2.1	1.0

3.9

Parts Relation and Timing

3.9.1

Needle and Needle Plate

When needle at the highest position, distance 'A' between needle point (the left needle if there are two needles) and needle plate is 9.5 to 9.7 mm for standard adjustment, or 10.8 to 11.0 mm for specific cases. Each needle should be centralized over each hole in the needle plate. The right needle must be about 0.2 to 0.3 mm ahead the left needle.

Distance between needle point (the right needle if there are two needles) and the front part of the hole in the needle plate or presser foot is 1.2 mm.

Release screw '1', as shown on figure 16.

Turn the wheel to see if needle is centralized at every hole of the needle plate. Release screw '2' to adjust needle holder.

Turn the wheel to move needle to the highest position and move needle bar until the height is correctly adjusted.

Tighten screws '1' and '2'.

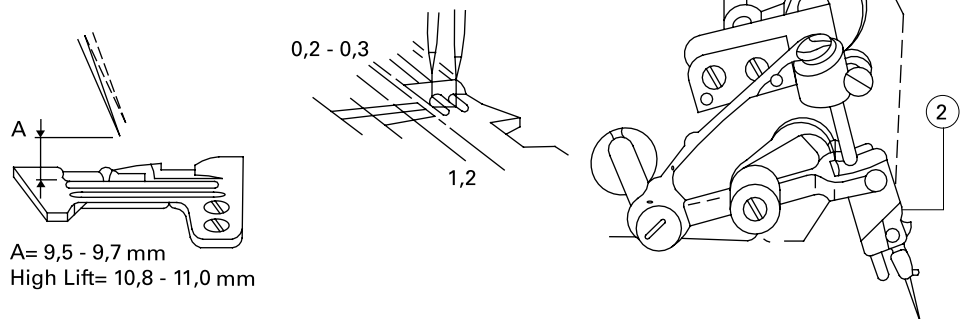

Figure 16

3.9.2

Upper Looper (Spreader) and Needle

When the right looper moves to the far left end, distance 'A' between the looper point and the center line of the needle is 4.5 to 5.0 mm for one

needle. For two needles, the distance 'B' is 5.5 to 6.0 mm from the left needle, as shown on figure 17.

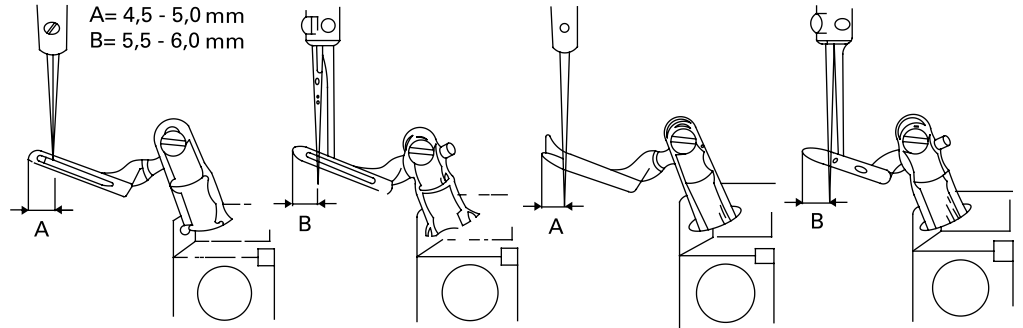

Figure 17

3.9.3

Lower Looper and Needle

When the lower looper moves to the extremely left, the distance 'A' between looper point and center line of the needle (left needle, if two needles) is from 3.4 to 3.6 mm, for high lift machines, as shown on figure 18.

When the lower looper moves to the center line of needle (left needle, if two needles), the gap between needle and looper is from 0 to 0.05 mm, as shown on figure 19.

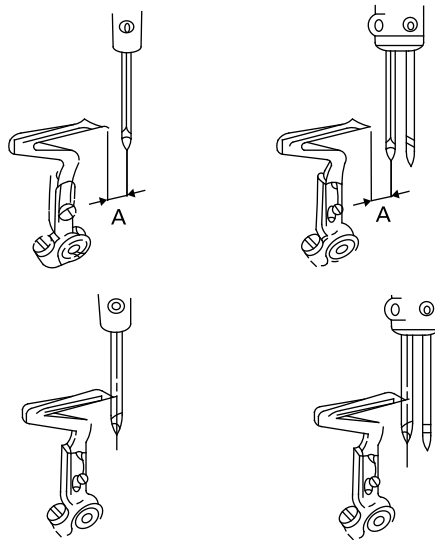

Figure 18

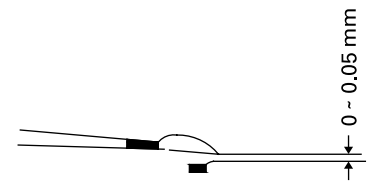

Figure 19

From the library of: Diamond Needle Corp

3.9.4

Upper and Lower Loopers

When the upper and lower loopers are crossed, the distance is 0.2 mm for 'A' and 0.5 mm for 'B', according to figure 20.

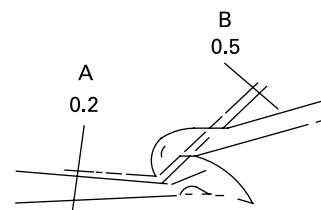

Figure 20

3.9.5

Needle and Needle Guard

When the looper point is on the side opposite to the center line of the needle (left needle if there are two needles), space between needle and rear needle guard of 'A' is 0 mm. When needle moves to the lowest position, space between needle and front needle guard of 'B' is from 0.15 to 0.20 mm, according to figure 21.

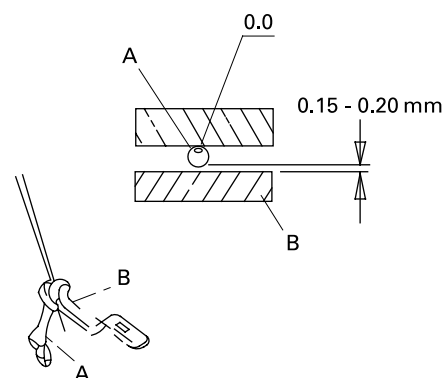

Figure 21

3.9.6

Chain Looper and Needle

The safety looper should be fixed in a position lower than this support.

And when it moves to the left far end, the distance between the looper point and the center line of needle is 2.5 mm, according to figure 22.

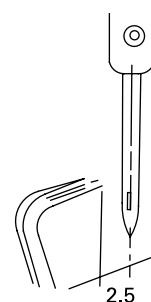

Figure 22

4

Maintenance

4.1

Machine Head Cleaning

Clean the machine head periodically with a dry soft cloth to remove the excess of dust in the head. Do not use any kind of solvent material to clean the surface.

4.2

Oil Change and Filter Cleaning

If the machine has not been used for a long time, lubricate the superior part of the needle bar, guides and loopers before returning to operation.

Oil filter should be cleaned every month or replaced for a new one as necessary. To clean the filter or change the oil, follow instruction in item 3.3.

Oil should be changed every four months. When changing the oil follow instructions on item 3.3.

4.3

Safety Inspection

Frequently check if all safety devices are properly installed and adjusted.

Check and be sure there is no motor overheating and be sure that the cable and electric connectors are not damaged.

Check all screws that fix and hold the machine head that should be properly tight.

Check and be sure the belt is not excessively worn out and see that it has the proper tension.

5

Troubleshooting

Problems	Possible Causes	Possible Solutions
Broken needle	1. Needle installed the wrong way.	1. Install the needle correctly.
	2. Wrong kind of needle.	2. Use needle adequate for cloth and thread.
	3. Damaged needle.	3. Replace for a new one.
	4. Wrong relation with needle guards.	4. Adjust needle guards.
	5. Wrong relation with looper.	5. Adjust the looper.
	6. Needle is not centralized with the hole at the needle plate or the presser foot.	6. Adjust the needle plate or the presser foot.
Broken thread	1. Low quality thread.	1. Use good quality thread.
	2. Thread is thicker than the eye of the needle.	2. Use adequate needle to cloth and thread.
	3. Wrong passage of thread.	3. Pass thread correctly.
	4. Thread tension too tight.	4. Adjust the thread tension unit.
	5. Needle wrongly set.	5. Set needle correctly.
	6. Thread stand wrongly set.	6. Set the thread stand correctly.
	7. Needle overheating.	7. Fill in silicon oil or adjust needle guards.
	8. Tension disk or guides with burrs .	8. Replace the parts.
	9. Wrong relation of needle with looper .	9. Adjust the synchronism of needle and looper.
	10. Needle, looper, needle plate and guides have burrs.	10. Replace the part.
Failure in stitches	1. Wrong relation of needle with looper.	1. Adjust the relation of needle with looper.
	2. Wrong passage of thread.	2. Pass thread correctly.
	3. Needle installed the wrong way.	3. Install needle correctly.
	4. Inadequate tension of thread.	4. Adjust thread tension button.
	5. Point of looper damaged.	5. Replace the part.
	6. Needle damaged.	6. Replace for a new needle.
	7. Wrong installation of needle guards.	7. Adjust the needle cover.
Skip stitches	1. Wrong threading.	1. Pass thread correctly.
	2. Thread is thicker than needle hole.	2. Use proper needle hole for cloth and thread.
	3. Wrong thread tension.	3. Adjust the thread tension units.
	4. Needle thread is not lubricated.	4. Fill in the silicon oil.
	5. Wrong relation of needle with looper.	5. Adjust the needle and looper.

5

Troubleshooting

Problems	Possible Causes	Possible Solutions
Uneven Stitches	1. Wrong threading.	1. Threading correctly.
	2. Wrong installation of thread stand.	2. Install thread support correctly.
	3. Wrong setting of lower knife.	3. Adjust lower knife correctly.
	4. Knives does not cut perfectly.	4. Adjust or replace knives.
	5. Thread guide or tension disc with burrs.	5. Replace the part.
	6. Needle point damaged.	6. Replace the needle.
	7. Inadequate height of feed dog.	7. Adjust the height of feed dog.
	8. Inadequate thread tension.	8. Adjust thread tension.
Puckering	1. Thread tension is too strong.	1. Adjust thread tension.
	2. Inadequate pressure on presser foot.	2. Adjust pressure on presser foot.
	3. Inadequate height of feed dog.	3. Adjust the height of feed dog.
	4. Knives does not cut perfectly.	4. Adjust or replace knives.
	5. Differential feed is not correct.	5. Adjust differential feed ratio.
	6. Needle is too thick.	6. Use proper needle to cloth and thread.
Poor chain-off stitches	1. Incorrect presser foot.	1. Adjust presser foot correctly.
	2. Inadequate synchronism of looper cam.	2. Adjust looper cam.
	3. Chain stitch looper installed wrongly.	3. Adjust looper correctly.
	4. Wrong passage of thread.	4. Pass thread correctly.
	5. Thread tension inadequate.	5. Adjust thread tension.
	6. Wrong relation of needle with looper.	6. Adjust relation of needle with looper.
	7. Needle plate or presser foot with burr.	7. Replace the part.
	8. Rough thread tension disc.	8. Polish thread tension disc.

6

Parts List

6.1

Frame
Components

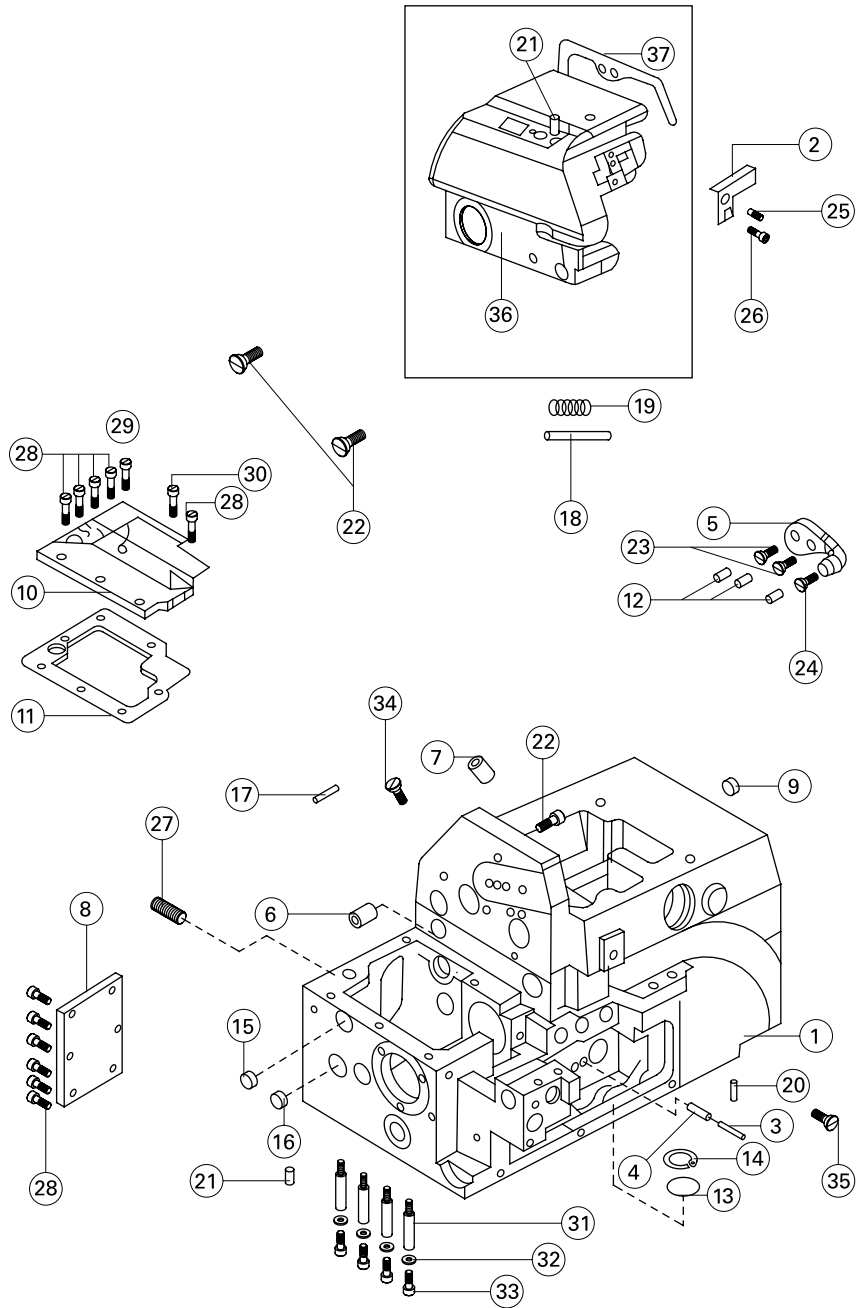

6.1

Frame Components

No.	Part No.	Description	Qty		
			3 thread	4 thread	5 thread
1	20101069	Machine frame	1	1	1
2	20112001	Needle thread cover plate	1	1	1
3	P01003	Pin	1	1	1
4	20523003	Oil wick	1	1	1
5	20101003	Needle plate	1	1	1
6	20122002	Rear oil adhesive	1	1	1
7	20122003	Oil seal	1	1	1
8	20112002	Rear cover	1	1	1
9	20122005	Oil cover	1	1	1
10	20101004	Cover	1	1	1
11	20122007	Cover washer	1	1	1
12	P01003	Pin	3	3	3
13	20112003	Oil screen	1	1	1
14	H01003	Snap ring	1	1	1
15	20122008	Oil seal I	2	2	1
16	20122009	Oil seal II	1	1	1
17	20626004	Oil amount adjusting pin	1	1	1
18	20121019	Oil tube	1	1	1
19	20127001	Spring	1	1	1
20	20126001	Pin	2	2	2
21	20121019	Oil tube	1	1	1
22	201S11028	Screw	3	3	3
23	201S11027	Screw	2	2	2
24	201S11029	Screw	1	1	1
25	S10005	Screw M3x3	1	1	1
26	201S11033	Screw	1	1	1
27	201S14002	Screw	1	1	1
28	201S11016	Screw	11	11	11
29	201S12005	Screw	1	1	1
30	201S12006	Screw	1	1	1
31	201S30006	Screw	4	4	4
32	20128023	Washer	4	4	4
33	201S13002	Screw	4	4	4
34	201S11021	Screw	1	1	1
35	201S11039	Screw	1	1	1
36	20101065	Side cover	1	1	1
37	20122041	Side cover pad	1	1	1

6.2

Cloth Plate Components

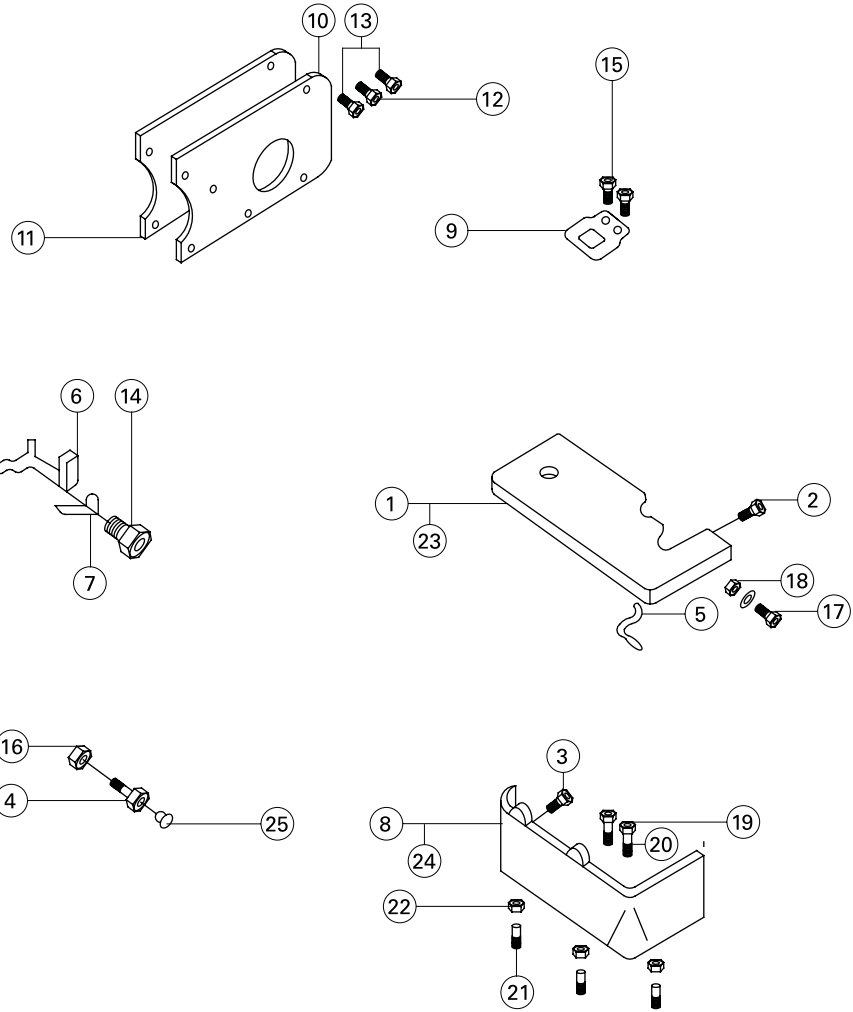

6.2

Cloth Plate Components

No.	Part No.	Description	Qty		
			3 thread	4 thread	5 thread
1	2011207900	Cloth plate	1	1	0
2	20122012	Rubber bushing	1	1	1
3	20122013	Rubber bushing	1	1	1
4	201S30011	Screw	1	1	1
5	20127003	Spring	1	1	1
6	20112011	Cloth plate slider cover	1	1	1
7	20127004	Cloth plate cover spring	1	1	1
8	20111022	Cloth plate lower plate	1	1	0
9	20111003	Washer	1	1	1
10	20112012	Upper looper sealing plate	1	1	1
11	20122015	Upper looper sealing plate washer	1	1	1
12	201S11018	Screw	1	1	1
13	201S11016	Screw	2	2	2
14	201S20003	Screw	1	1	1
15	201S17004	Screw	2	2	2
16	201S16003	Nut	1	1	1
17	201S30007	Screw	1	1	1
18	201S16001	Nut	1	1	1
19	W01005	Washer 3	2	2	2
20	201S11005	Screw	2	2	2
21	201S11037	Screw	3	3	3
22	20128019	Washer	3	3	3
23	2011200500	Cloth plate	0	0	1
24	20111002	Cloth plate lower plate	0	0	1
25	20122011	Rubber bushing	1	1	1

6.3

Cover
Components

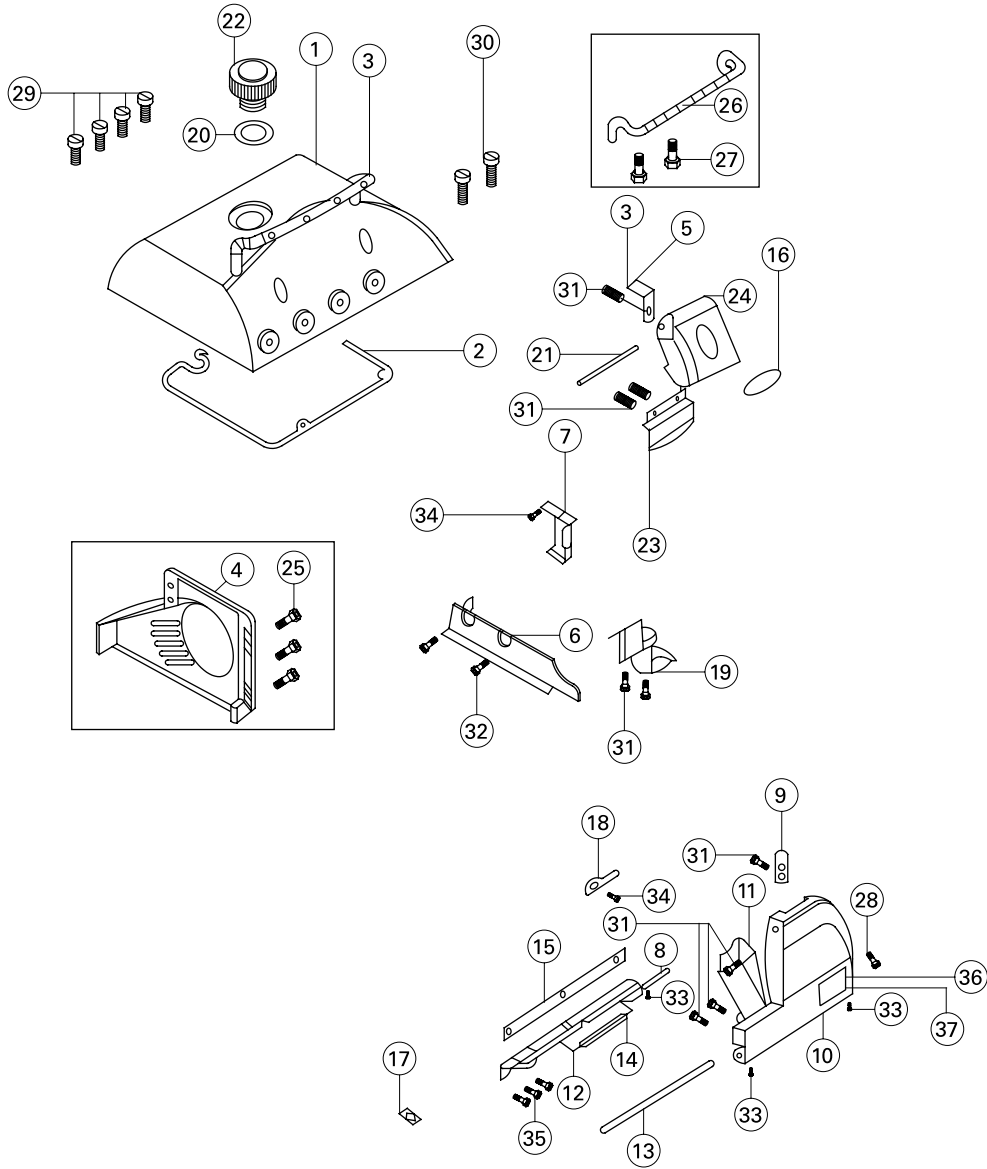

6.3

Cover Components

No.	Part No.	Description	Qty		
			3 thread	4 thread	5 thread
1	20111019	Upper cover	1	1	1
2	20122016	Upper cover washer	1	1	1
3	20112080	Thread guide supporter	1	1	1
4	20211001	Belt cover	1	1	1
5	20112014	Thread cover spring	1	1	1
6	20112015	Cloth guide plate	1	1	1
7	20112016	Oil guide II	1	1	1
8	20126003	Pin	1	1	1
9	20112017	Front spring	1	1	1
10	20101067	Front cover	1	1	1
11	20112018	Front cover guard	1	1	0
	20112019	Front cover guard	0	0	1
12	20101007	Front cover hinge	1	1	1
13	20126004	Hinge pin	1	1	1
14	20127005	Front cover hinge spring	1	1	1
15	20122017	Front cover hinge washer	1	1	1
16	20137002	Trade mark plate	1	1	1
17	20131064	Oil flow window	2	2	2
18	20112020	Front cover snap guard	1	1	1
19	20112021	Oil guard	1	1	1
20	20122018	Oil level gauge washer	1	1	1
21	20126005	Pin	1	1	1
22	20111005	Oil sight window	1	1	1
23	20111021	Eye Guard	1	1	1
24	20111019	Upper cover	1	1	1
25	201S11024	Screw	3	3	3
26	20313001	Thread guide supporter	1	1	1
27	S01010	Screw	2	2	2
28	H05002	Snap spring	1	1	1
29	201S11036	Screw	4	4	4
30	206S11005	Screw	2	2	2
31	201S11009	Screw	9	9	9
32	201S11018	Screw	2	2	2
33	201S15001	Screw	3	3	3
34	201S11014	Screw	2	2	2
35	201S11038	Screw	3	3	3
36	R03001	Rivet	2	2	2
37	20137005	Machine model plate	1	1	1

6.4

Main Shaft Components

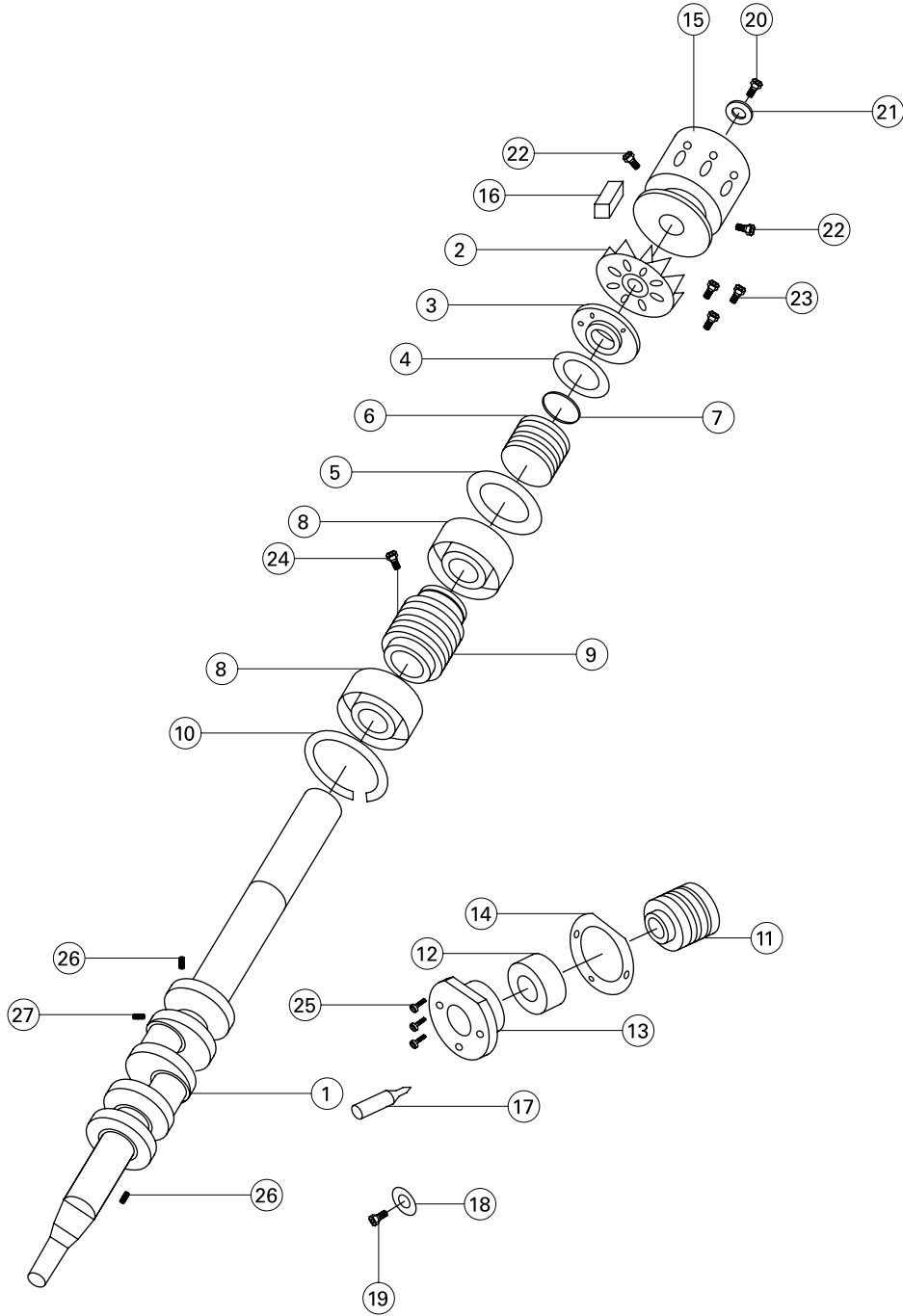

6.4

Main Shaft Components

No.	Part No.	Description	Qty		
			3 thread	4 thread	5 thread
1	20102001	Main shaft	1	1	1
2	20111008	Wheel	1	1	1
3	20101008	Rear shaft bearing cover	1	1	1
4	20122019	Washer	1	1	1
5	20128002	Main shaft spring washer	1	1	1
6	20103002	Oil seal	1	1	1
7	O01003	Seal ring	1	1	1
8	B03001	Bearing	2	2	2
9	20125001	Oil pump worm	1	1	1
10	20129001	Snap spring	1	1	1
11	20103003	Main shaft left bushing	1	1	1
12	B04001	Bearing	1	1	1
13	20101009	Bearing cover	1	1	0
	20101010	Bearing cover	0	0	1
14	20122020	Bearing cover washer	1	1	1
15	20101044	Pulley	1	1	1
16	20101012	Key	1	1	1
17	20126006	Bulgy pulley shaft	0	0	1
18	30128008	Washer	1	1	0
19	201S11040	Screw	1	1	0
20	201S11034	Screw	1	1	1
21	20128024	Washer	1	1	1
22	201S15004	Screw	2	2	2
23	201S11016	Screw	3	3	3
24	201S14002	Screw	1	1	1
25	201S11012	Screw	3	3	3
26	201S15005	Screw	2	2	2
27	201S15001	Screw	1	1	1

6.5

Needle Bar Components

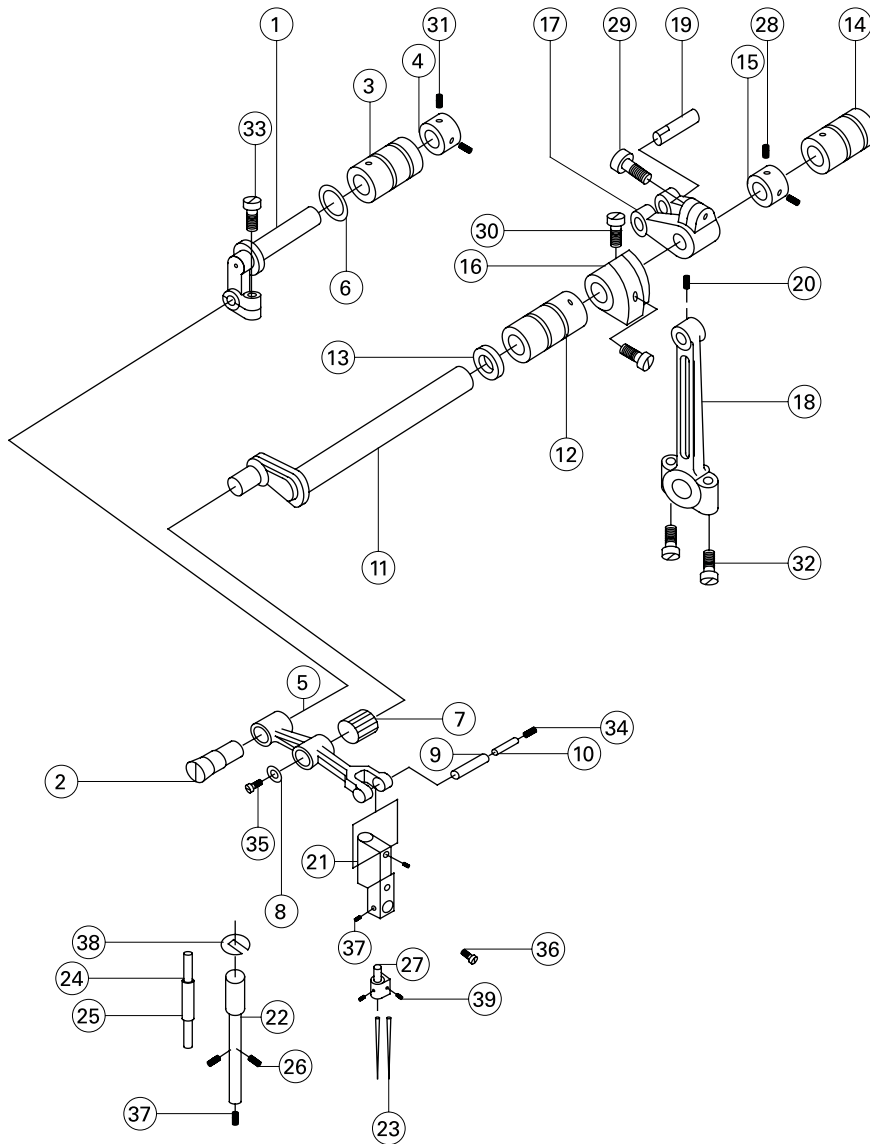

6.5

Needle Bar Components

No.	Part No.	Description	Qty		
			3 thread	4 thread	5 thread
1	20102002	Needle bar driving frame rock shaft	1	1	1
2	20126007	Eccentric shaft	1	1	1
3	20103004	Needle bar shaft bushing back	1	1	1
4	20108001	Thrust collar	1	1	1
5	20104001	Needle bar driving crank	1	1	1
6	20122022	Oil seal	1	1	1
7	B07006	Needle bearing	1	1	1
8	20128004	Washer ring	1	1	1
9	20126008	Needle bar guide pin	1	1	1
10	20123021	Oil wick	1	1	1
11	20102003	Needle bar rock shaft	1	1	1
12	20103005	Needle bar shaft bearing (left)	1	1	1
13	20122021	Seal ring	2	2	2
14	20103006	Needle bar shaft bearing (right)	1	1	1
15	20108002	Thrust collar	2	2	2
16	20101013	Balance block	1	1	1
17	20104002	Needle bar frame rock shaft crank	0	1	0
	20104003	Needle bar frame rock shaft crank	1	0	1
18	20105001	Needle bar connecting rod	1	1	1
19	20126009	Connecting link pin	1	1	1
20	201S12005	Screw	1	1	1
21	20101014	Needle bar guide bracket	1	1	1
22	2010200400	Needle bar	1	1	1
23	20117012	Cat No. 6120-06 Needle	1	2	0
	20117013	Cat No. 6120-06 Needle	0	0	2
	20117014	Cat No. 6120-06 Needle	0	0	2
24	20123021	Oil wick	1	1	1
25	20121020	Plastic tube	1	1	1
26	20123005	Oil wick	2	2	2
27	20134002	Needle clamp	1	0	0
	20134001	Needle clamp	0	1	0
	20134003	Needle clamp	0	0	1
	20134004	Needle clamp (for thick)	0	0	1
28	201S15003	Thrust collar set screw	2	2	2
29	201S13003	Hexagon socket screw	1	1	1
30	201S30003	Balance block position screw	2	2	2
31	201S14002	Thrust collar set screw	3	3	3
32	201S20006	Needle bar connecting rod set screw	2	2	2
33	201S11026	Screw	1	1	1
34	201S17001	Screw	1	1	1
35	201S17004	Screw	1	1	1
36	S01022	Screw	1	1	1
37	S010005	Screw	4	4	4
38	H05008	Snap ring	1	1	1
39	201S14001	Screw	2	2	

6.6

Thread Guide Components

No.	Part No.	Description	Qty		
			3 thread	4 thread	5 thread
13	20111009	Silicon oil box	1	1	1
14	20112022	Oil felt	1	1	1
15	20113005	Thread guide	1	1	1
16	20122023	Silicon oli washer	1	1	1
17	20123006	Oil felt	1	1	1
18	20113006	Tension spring	1	1	1
19	20113007	Thread controller disc holder	1	1	1
20	20127006	Spring	1	1	1
21	20103008	Thread controller disc guide bushing	1	1	1
22	20101015	Throat plate positioning rod	2	2	2
23	20101016	Throat plate bracket	1	1	1
24	20113008	Thread mark guide	1	1	0
	20113009	Thread mark guide	0	0	1
25	20117002	Teat needle guard	1	1	1
26	20117003	Front needle guard	1	0	0
	20117004	Front needle guard	0	1	0
27	20115001	Needle plate	1	0	0
	20115002	Needle plate	0	1	0
	20115003	Needle plate	0	0	1
	20115004	Needle plate	1	0	0
	20115005	Needle plate	0	1	0
	20115006	Needle plate	1	0	0
	20115007	Needle plate	0	0	1
	20115008	Needle plate	0	0	1
	20115010	Needle plate	1	0	0
28	20113010	Thread guide	0	0	1
29	20117005	Needle guard I	0	0	1
30	20117006	Needle guard II	0	0	1
31	20101017	Needle guard bracket	1	1	0
	20101018	Needle guard bracket	0	0	1
32	20101019	Snap plate	1	1	1
33	20122024	Snap plate washer	1	1	1
34	W01011	Washer	1	1	1
35	201S17005	Throat screw	2	2	2
36	201S11008	Front needle guard screw	1	1	1
37	201S11029	Throat plate bracket screw	2	2	2
38	201S11014	Thread guide holder screw	1	1	1
39	201S11001	Silicon oil box set screw	1	1	1
40	201S20005	Silicon oil box set screw	1	1	1
41	201S11003	Rear needle guard screw	2	2	2
42	201S12009	Needle guard screw	3	3	3
43	201S11009	Thread take up screw	2	2	2
44	201S15001	Snap plate screw II	1	1	1
45	201S30010	Snap plate set screw	1	1	1
46	201S11022	Screw	2	2	2
47	201S11018	Screw	1	1	1
48	20128030	Washer	1	1	1
49	S01006	Screw	1	1	1
50	20122011	Rubber bushing	2	2	2

6.7

Upper Looper Components

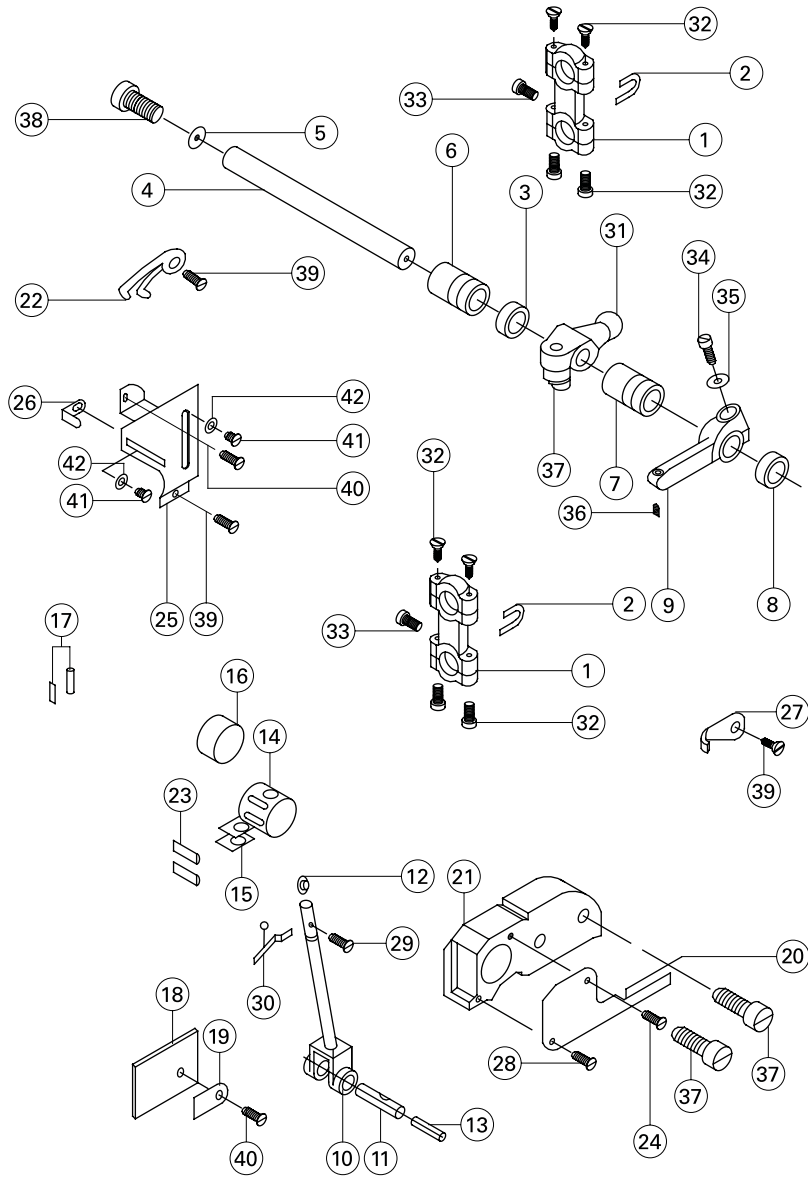

6.7

Upper Looper Components

No.	Part No.	Description	Qty		
			3 thread	4 thread	5 thread
1	20105002	Looper link	2	2	2
2	20126010	Looper link holder	2	2	2
3	20128005	Thickness washer	1	1	1
4	20102006	Upper looper shaft	1	1	1
5	20128007	Big washer	1	1	1
6	20103009	Upper looper shaft rear bushing	1	1	1
7	20103010	Upper looper shaft front bushing	1	1	1
8	20122025	Upper looper shaft oil seal	1	1	1
9	20104004	Upper looper shaft crank	1	1	1
10	20104005	Upper looper shaft bar	1	1	1
11	20126011	Connecting rod shaft pin	1	1	1
12	20112023	Washer	1	1	1
13	20123021	Oil wick	1	1	1
14	20109001	Upper looper slide block	1	1	1
15	20123008	Oil felt	2	2	2
16	20123009	Oil felt	1	1	1
17	20113013	Thread tube	2	2	2
18	20112024	Screen oil plate	1	1	1
19	20112025	Felt plate	1	1	1
20	20112026	Thread holder snap plate	1	1	1
21	20101020	Upper looper shaft slide bar bracket	1	1	1
22	20113014	Thread guide	1	1	1
23	20523003	Oil wick	1	1	1
24	201S11005	Screw	1	1	1
25	20112027	Thread amount regulating plate	1	1	1
26	20113011	Upper looper thread guard	1	1	1
27	20113012	Upper looper shaft thread plate	1	1	1
28	201S17006	Screw	1	1	1
29	201S11007	Upper looper set screw	1	1	1
30	20117007	Upper looper	1	1	1
31	20104006	Upper looper crank	0	1	1
	20104007	Upper looper crank	1	0	0
32	201S20006	Screw	8	8	8
33	201S11035	Screw	2	2	2
34	201S12007	Upper looper crank screw	1	1	1
35	20128021	Washer	1	1	1
36	S10005	Link pin set screw	1	1	1
37	201S13003	Hexagon socket screw	3	3	3
38	201S12005	Upper looper shaft screw	1	1	1
39	201S11016	Thread guide screw	3	3	3
40	201S11014	Screw	2	2	2
41	201S11006	Thread guide screw	2	2	2
42	20128020	Thread guide washer	2	2	2

6.8

Lower Loper Components

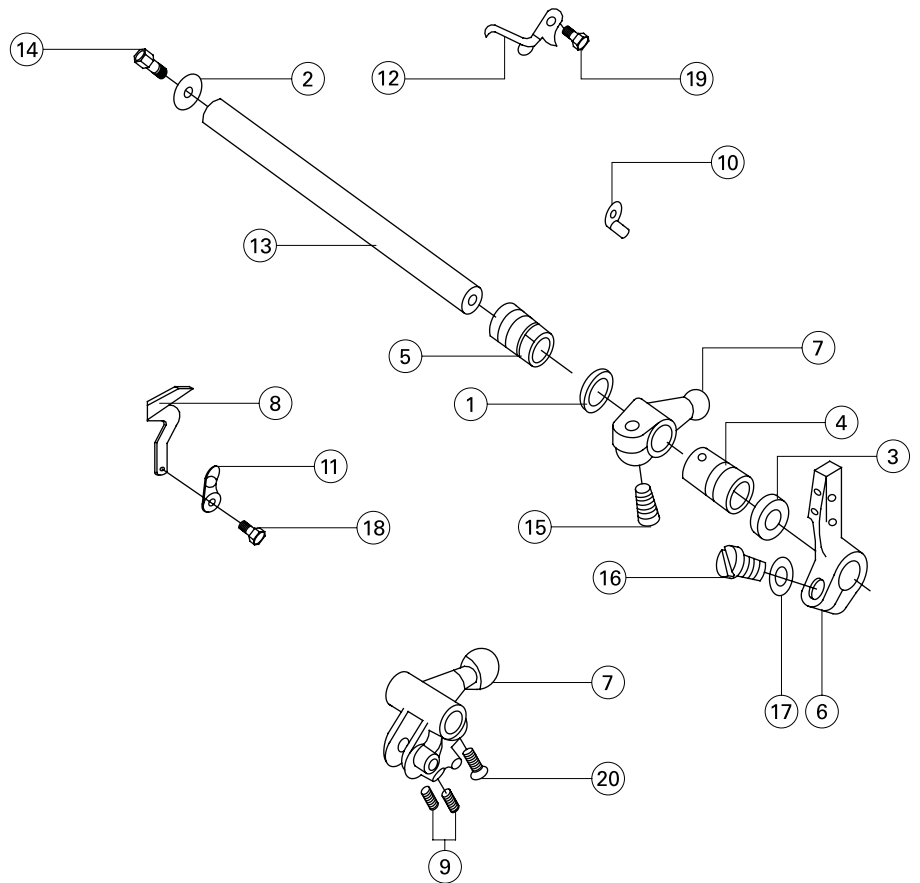

No.	Part No.	Description	Qty		
			3 thread	4 thread	5 thread
1	20128009	Washer	1	1	1
2	20128007	Lower looper shaft washer	1	1	1
3	20622019	Oil seal	1	1	1
4	20103011	Lower looper shaft bushing (front)	1	1	1
5	20103015	Lower looper shaft bushing (rear)	1	1	1
6	20104008	Lower looper holder	1	1	0
	20104025	Lower looper holder	0	0	1
7	20104009	Lower looper crank	1	1	0
	20104010	Lower looper crank	0	0	1
8	20117008	Lower looper	1	1	0
	20117009	Lower looper	0	0	1
9	201S11007	Crank screw	0	0	2
10	20113015	Thread guide	1	1	1
11	20113016	Lower looper thread guide	1	1	1
12	20113017	Lower looper thread guide	1	1	1
13	20102007	Lower looper shaft	1	1	0
	20102008	Lower looper shaft	0	0	1
14	201S12005	Low looper shaft screw	1	1	1
15	201S13003	Crank screw	1	1	1
16	201S12007	Lower looper holder screw	1	1	1
17	20128021	Lower looper holder washer	2	2	2
18	206S11002	Lower looper screw	1	1	1
19	201S11016	Thread guide screw	1	1	1
20	301S30013	Crank screw	0	0	

6.9

Front Loper Components

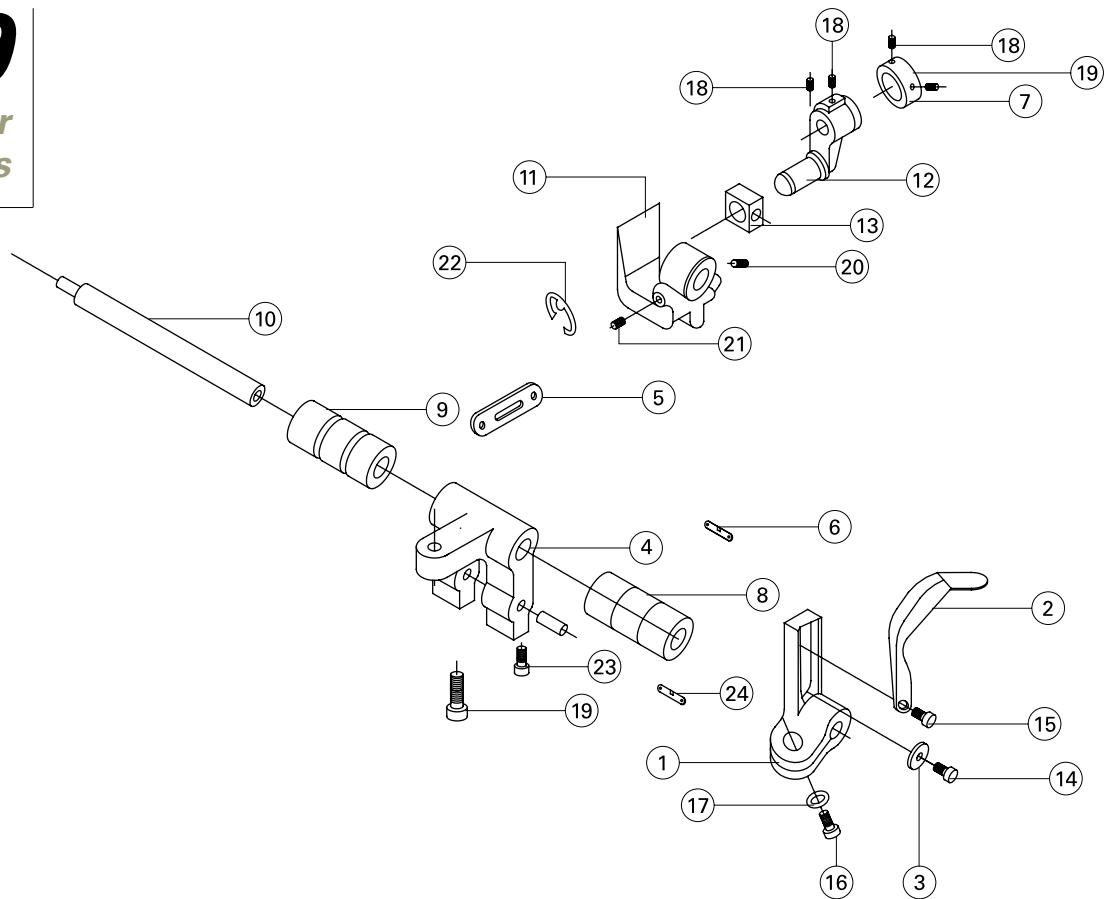

No.	Part No.	Description	Qty		
			3 thread	4 thread	5 thread
1	20104011	Front looper shaft holder	0	0	1
2	20117010	Front looper	0	0	1
3	20128014	Washer	0	0	1
4	20104012	Front looper crank	0	0	1
5	20609017	Regulating plate	0	0	1
6	20126013	Regulating plate pin	0	0	2
7	20108001	Driving crank holder	0	0	1
8	20103013	Front looper shaft bushing (front)	0	0	1
9	20103014	Front looper shaft bushing (rear)	0	0	1
10	20102009	Front looper shaft	0	0	1
11	20101021	Driving lever	0	0	1
12	20104013	Front looper driving crank	0	0	1
13	20109002	Front looper slide block	0	0	1
14	201S11003	Thread guide screw	0	0	1
15	201S11008	Front looper guide set screw	0	0	1
16	201S12007	Front looper holder set screw	0	0	1
17	20128021	Washer	0	0	1
18	201S12002	Screw	0	0	4
19	201S13003	Front looper crank screw	0	0	1
20	201S14002	Screw	0	0	1
21	201S30009	Screw	0	0	1
22	20129003	Snap ring	0	0	1
23	201S12005	Screw	0	0	1
24	20126022	Regulating plate pin	0	0	1

6.10

Cam
Components

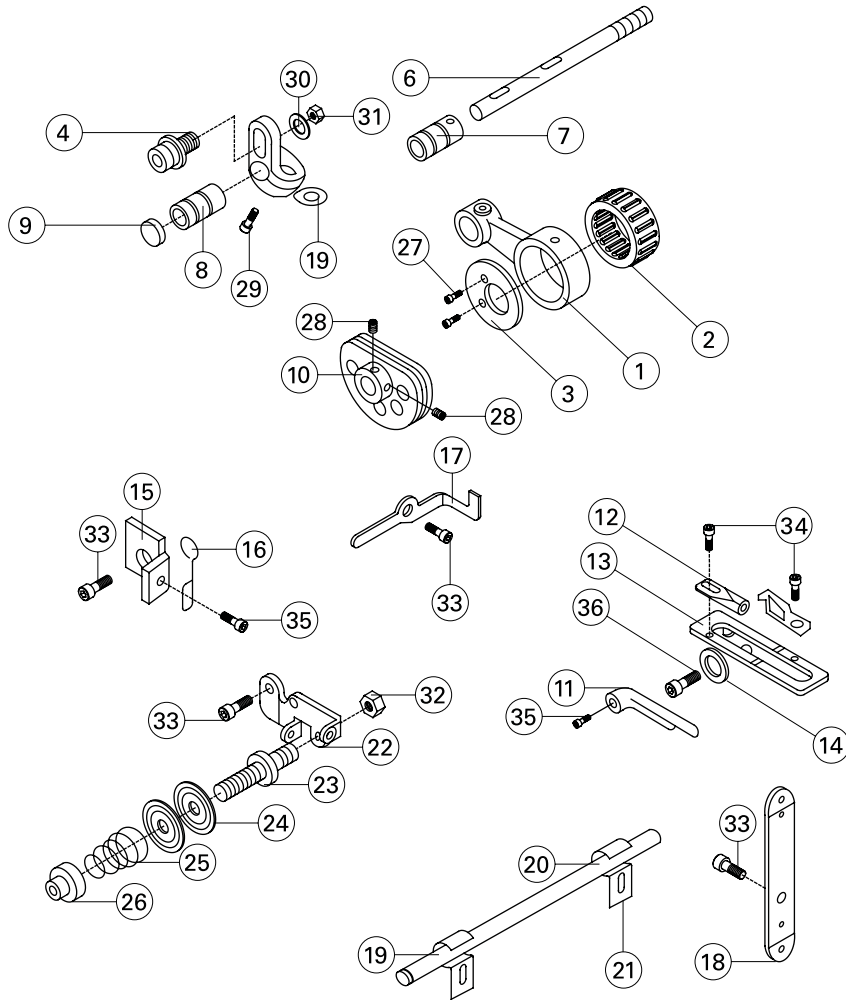

6.10

Cam Components

No.	Part No.	Description	Qty		
			3 thread	4 thread	5 thread
1	20105003	Horizontal shaft link	0	0	1
2	20124002	Needle bearing	0	0	1
3	20112028	Snap ring	0	0	1
4	20126014	Pin	0	0	1
5	20104014	Horizontal shaft crank	0	0	1
6	20102010	Horizontal shaft	0	0	1
7	20103015	Left horizontal shaft bushing	0	0	1
8	20103016	Right horizontal shaft bushing	0	0	1
9	20122028	Oil seal	0	0	1
10	2011301800	Looper thread take-up cam	0	0	1
11	20113020	Thread guide	0	0	1
12	20113021	Thread guide	0	0	2
13	20112029	Bracket	0	0	1
14	20128015	Flat spring	0	0	1
15	20112030	Thread guide position plate	0	0	1
16	20113022	Thread guide ring	0	0	1
17	20113023	Thread guide	0	0	1
18	20113024	Thread guide	0	0	1
19	20113025	Thread pipe cover	0	0	2
20	20113026	Thread pipe	0	0	1
21	20112031	Bracket	0	0	2
22	20112032	Bracket	0	0	1
23	201S30012	Screw	0	0	1
24	20112033	Tension disc	0	0	2
25	20127007	Spring	0	0	1
26	201S16007	Nut	0	0	1
27	201S17001	Bearing snap ring screw	0	0	2
28	201S14001	Cam set screw	0	0	2
29	201S13003	Crank set screw	0	0	1
30	20128033	Washer	0	0	1
31	201S16002	Nut	0	0	1
32	201S16003	Nut	0	0	1
33	201S11014	Screw	0	0	4
34	201S11001	Thread guide plate screw	0	0	2
35	201S11009	Thread guide plate screw	0	0	2
36	201S20001	Screw	0	0	1

6.11

Differential Feed Components

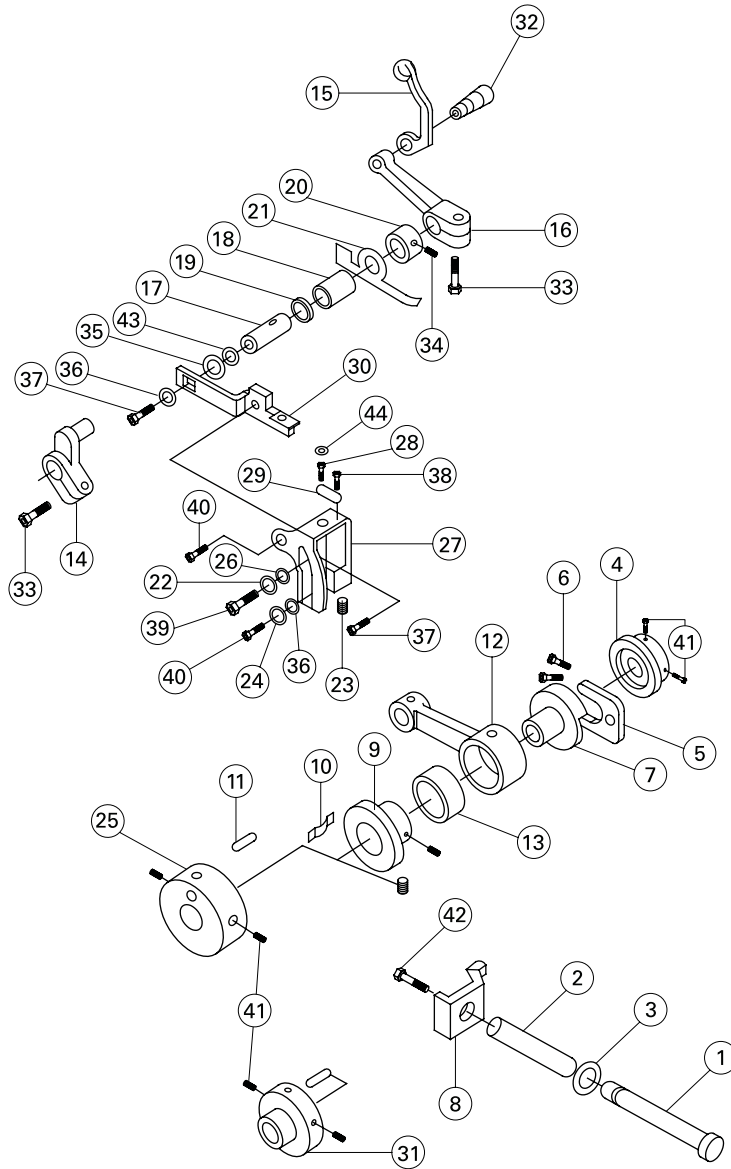

6.11

Differential Feed Components

No.	Part No.	Description	Qty		
			3 thread	4 thread	5 thread
1	20102011	Stitch length regulating shaft	1	1	1
2	20127008	Spring	1	1	1
3	O01016	Oil washer	1	1	1
4	2011000100	Stitch length regulation cam assembly	1	1	1
5	20109004	Stitch length regulating block	1	1	1
6	20127009	Stitch length regulating block spring	2	2	2
7	20110002	Stitch length cam	1	1	1
8	20112034	Stitch length regulating plate	1	1	1
9	20110003	Feed length cam	1	1	1
10	20112035	Feed cam spring	1	1	1
11	P01004	Feed cam pin	1	1	1
12	20105004	Feed link	1	1	1
13	B07007	Feed rod rolling pin bearing	1	1	1
14	20104015	Feed crank	1	1	1
15	20105005	Differential link	1	1	1
16	20104016	Differential crank	1	1	1
17	20102012	Differential shaft	1	1	1
18	20103017	Differential shaft bearing	1	1	1
19	20122029	Oil seal	1	1	1
20	20108005	Thrust collar	1	1	1
21	20127010	Spring	1	1	1
22	201S16008	Washer	1	1	1
23	20109005	Regulating block	1	1	1
24	20128027	Washer	1	1	1
25	20110004	Feed cam	1	1	0
26	20128028	Washer	1	1	1
27	20112036	Differential regulation holder	1	1	1
28	201S30013	Regulating screw	1	1	1
29	20127011	Regulating screw spring	1	1	1
30	20112037	Differential regulating link	1	1	1
31	2010402300	Crank link cam	0	0	1
32	201S20008	Differential link screw	1	1	1
33	201S13003	Differential crank screw	2	2	2
34	201S12002	Thrust collar set screw	1	1	1
35	20128024	Washer	1	1	1
36	W01006	Washer	2	2	2
37	201S11016	Differential position screw	1	1	1
38	201S11005	Spring screw	1	1	1
39	201S30005	Differential regulating screw	1	1	1
40	201S11018	Differential regulating screw	2	2	2
41	201S14002	Screw	4	4	4
42	201S12005	Screw	1	1	1
43	20122038	Washer	1	1	1
44	20137004	Marker plate	1	1	1

6.12

Feed Dog
Components

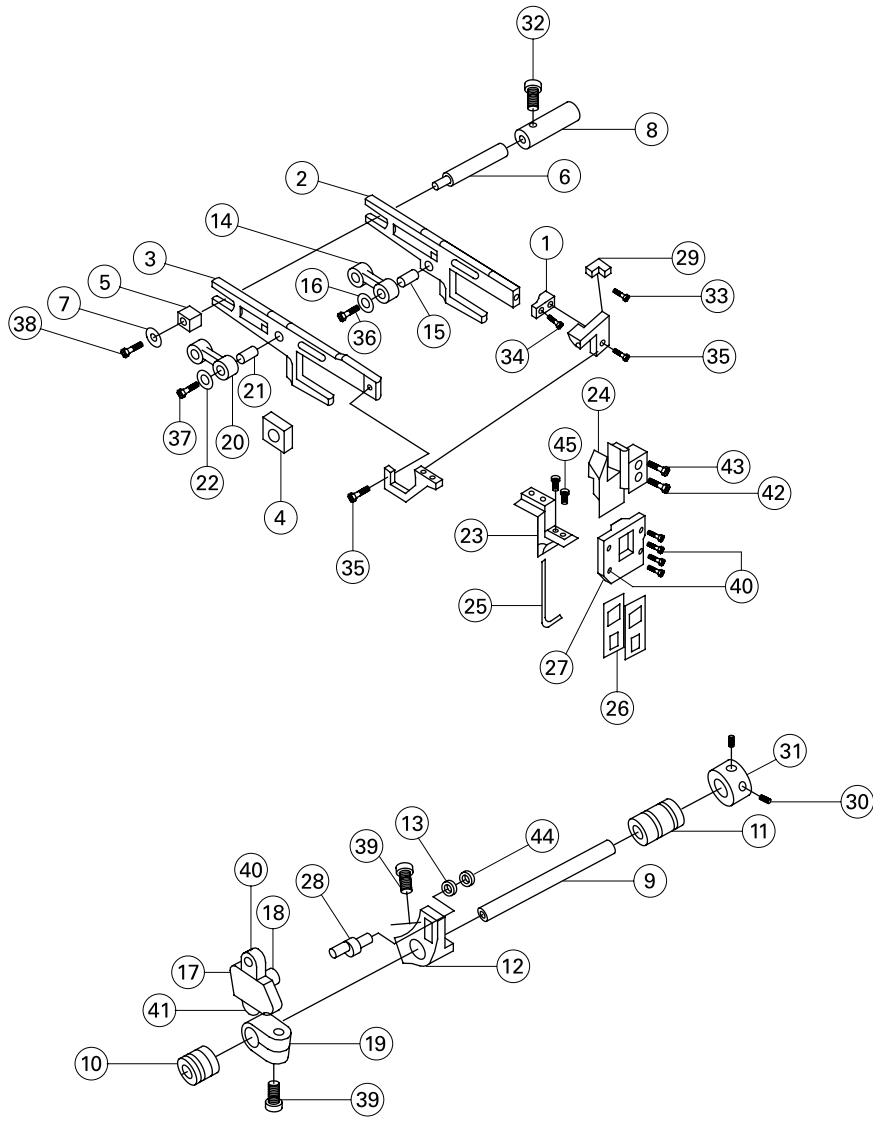

From the library of: Diamond Needle Corp

6.12

Feed Dog Components

No.	Part No.	Description	Qty		
			3 thread	4 thread	5 thread
1	20109006	Main feed dog link plate	1	1	1
2	20106001	Main feed dog bar	1	1	1
3	20106002	Differential feed dog bar	1	1	1
4	20109007	Feed dog lift slide block	1	1	1
5	20109008	Differential feed slide block	1	1	1
6	20102013	Slide block eccentric shaft	1	1	1
7	20112038	Slide block eccentric washer	1	1	1
8	20103018	Slide block eccentric shaft bushing	1	1	1
9	20102014	Feed shaft	1	1	1
10	20103019	Feed shaft bushing (left)	1	1	1
11	20103020	Feed shaft bushing (right)	1	1	1
12	20104017	Feed regulating crank	1	1	1
13	20128021	Washer	1	1	1
14	20105006	Main feed dog bar link	1	1	1
15	20103021	Main feed dog bar link bushing	1	1	1
16	20128029	Washer	1	1	1
17	20112039	Crank slide block cover	1	1	1
18	20109010	Crank slide block	1	1	1
19	20104018	Feed regulating crank	1	1	1
20	20105007	Differential feed dog bar link	1	1	1
21	20103022	Differential feed dog bar link bushing	1	1	1
22	20128030	Washer	2	2	2
23	20101023	Screw oil plate	1	1	1
24	20109011	Feed dog carrier connection rod	1	1	1
25	20122030	Sealing connecting ring	1	1	1
26	20122031	Adjustable oil seal	2	2	2
27	20109012	Sealing connecting rod	1	1	1
28	20102015	Feed dog link eccentric shaft	1	1	1
29	2011401700	Feed dog complete set	1	1	0
	2011401800	Feed dog complete set	1	0	0
	2011401900	Feed dog complete set	0	0	1
	2011402000	Feed dog complete set	0	0	1
30	201S15003	Thrust collar set screw	2	2	2
31	20108002	Thrust collar	1	1	1
32	201S12002	Screw	1	1	1
33	201S11003	Screw	1	1	1
34	201S11012	Screw	1	1	1
35	201S11038	Screw	2	2	2
36	201S12003	Screw	1	1	1
37	201S12004	Screw	1	1	1
38	201S17003	Screw	1	1	1
39	201S13003	Crank screw	2	2	2
40	201S11005	Crank	4	4	4
41	201S11032	Crank slide block screw	2	2	2
42	201S11018	Screw	1	1	1
43	201S11023	Screw	1	1	1
44	201S16002	Nut	1	1	1
45	201S11016	Screw	2	2	2

6.13

Trimming
Components

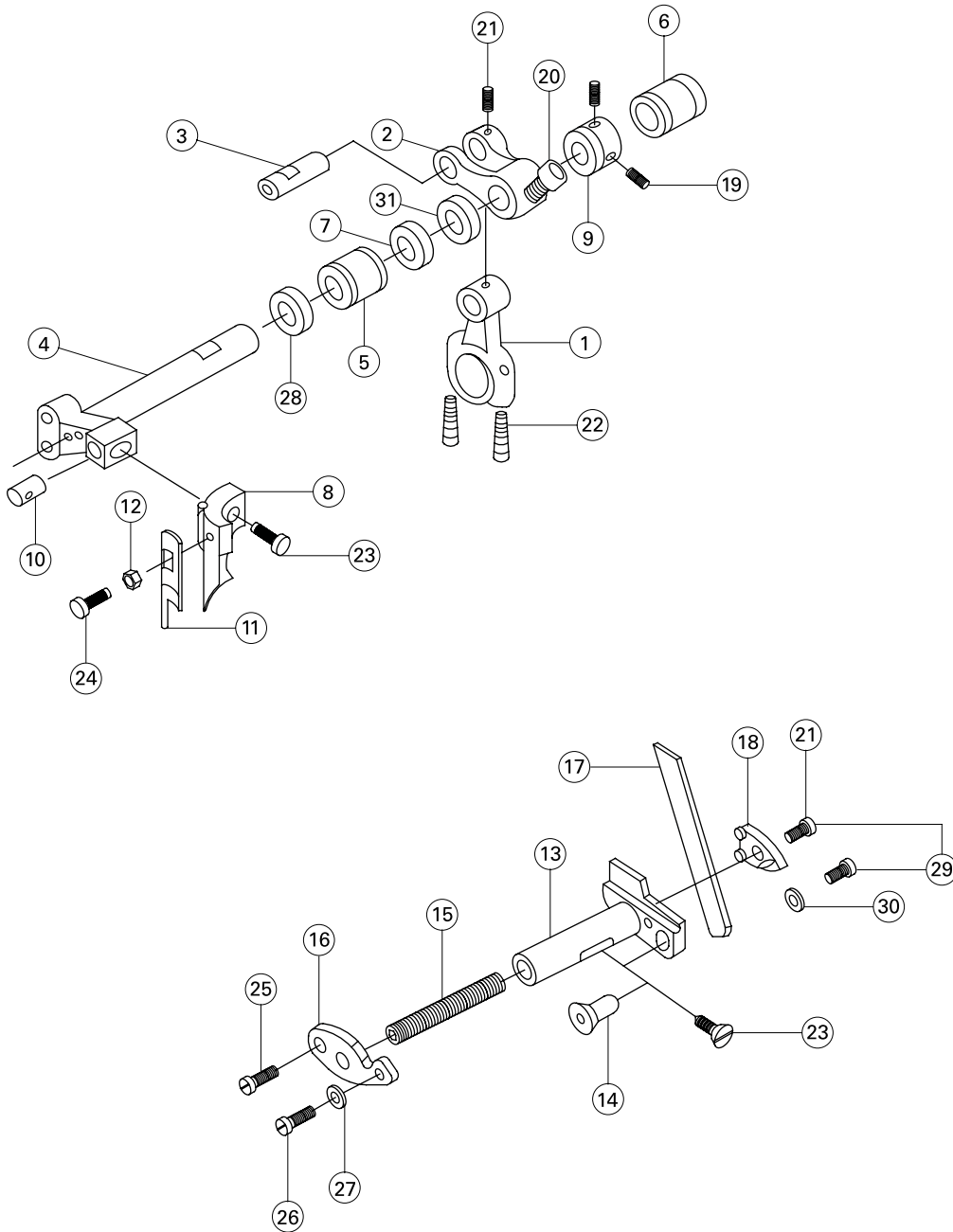

6.13

Trimming Components

No.	Part No.	Description	Qty		
			3 thread	4 thread	5 thread
1	20105008	Upper knife drive connecting link	1	1	1
2	20104019	Upper knife crank	1	1	0
	20104020	Upper knife crank	0	0	1
3	20126015	Crank pin	1	1	1
4	20102017	Upper knife frame rock shaft	1	1	1
5	20103023	Bushing (left)	1	1	1
6	20103024	Bushing (right)	1	1	1
7	20128031	Washer	1	1	1
8	20101024	Upper knife holder	1	1	0
	20101025	Upper knife holder	0	0	1
	20101053	Upper knife holder	0	0	1
9	20108002	Thrust collar	1	1	1
10	20126016	Upper knife holder pin	1	1	1
11	20119001	Upper knife	1	1	1
	20119005	Upper knife	0	0	1
12	20128020	Washer	1	1	1
13	20102018	Lower knife holder	1	1	0
	20102019	Lower knife holder	0	0	1
	20102023	Lower knife holder	1	1	0
14	20103025	Lower knife holder bushing	1	1	1
15	20127012	Lower knife holder spring	1	1	1
16	20112040	Lower knife holder plate	1	1	1
17	20119002	Lower knife	1	1	1
	20119006	Lower knife	0	0	1
18	20101026	Lower knife holder lock plate	1	1	1
19	201S15003	Thrust collar set screw	2	2	2
20	201S13003	Upper knife crank set screw	1	1	1
21	201S12005	Upper knife crank pin screw	2	2	2
22	201S20006	Connecting link screw	2	2	2
23	201S11022	Upper knife holder screw	2	2	2
24	201S12001	Upper knife screw	1	1	1
25	201S11017	Screw	1	1	1
26	201S11012	Screw	1	1	1
27	201S16001	Washer	1	1	1
28	20122038	Oil seal	1	1	1
29	201S11015	Lower knife holder screw	2	2	2
30	W01006	Washer	1	1	0
	20128025	Washer	0	0	1
31	20628014	Washer	1	1	1

6.14

Presser Foot Components

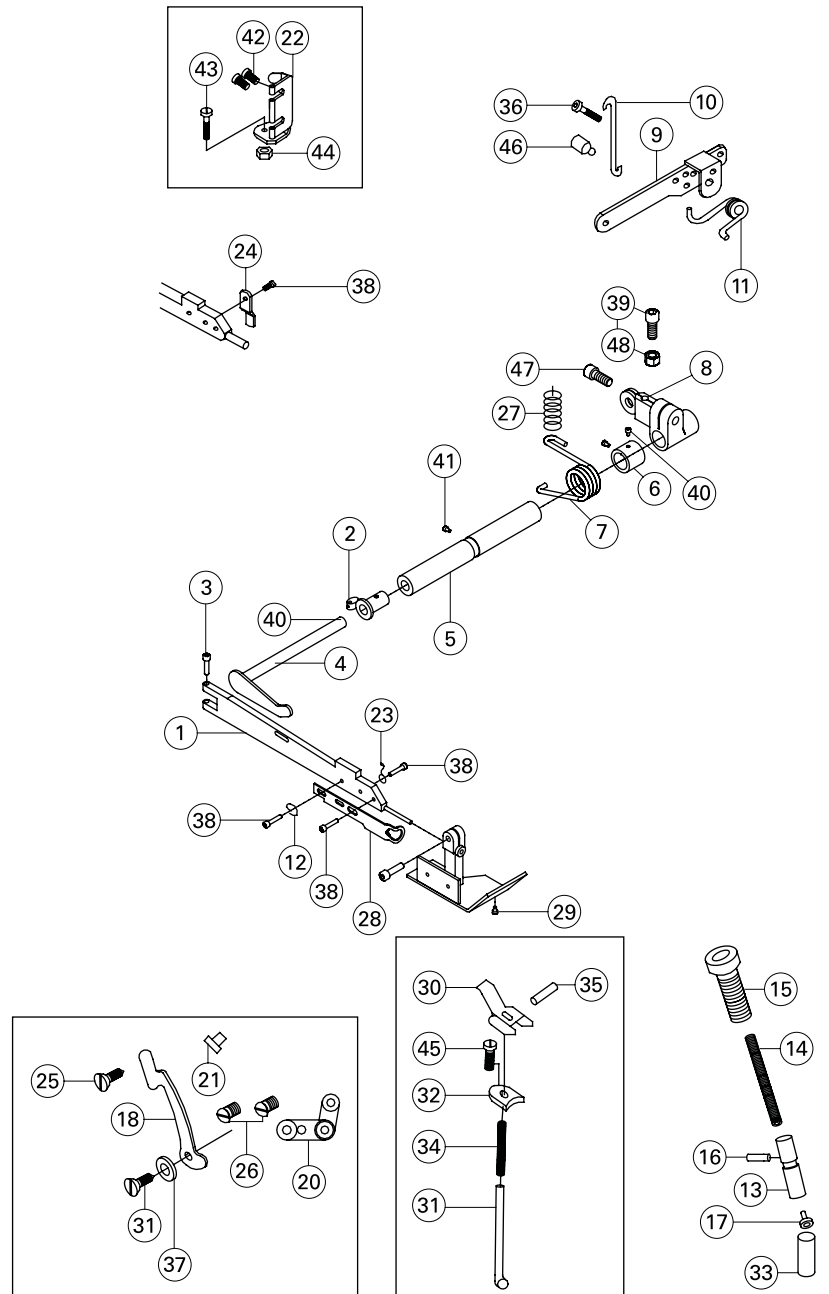

From the library of: Diamond Needle Corp

No.	Part No.	Description	Qty		
			3 thread	4 thread	5 thread
1	20101027	Presser foot arm	1	1	1
2	20103026	Presser foot shaft bushing	1	1	1
3	201S11004	Screw	1	1	1
4	20102020	Presser foot shaft	1	1	1
5	20103027	Presser foot shaft bushing	1	1	1

6.14

Presser Foot Components

No.	Part No.	Description	Qty		
			3 thread	4 thread	5 thread
6	20108006	Thrust collar	1	1	1
7	20127013	Presser foot lifting spring	1	1	1
8	20104021	Presser foot crank	1	1	1
9	20112041	Presser foot lifting lever	1	1	1
10	20126018	Lever hook	1	1	1
11	20127014	Spring	1	1	1
12	20119003	Thread cutting knife	1	1	1
13	20102021	Presser bar	1	1	1
14	20127015	Presser bar spring	1	1	1
15	201S30014	Presser bar screw	1	1	1
16	203S20001	Screw	1	1	1
17	20611006	Presser bar shockproof block	1	1	1
18	20112074	Presser foot lifting handle	1	1	1
19	20627010	Presser foot lifting handle spring	1	1	1
20	20101052	Presser foot lifting handle link	1	1	1
21	30122018	Washer	1	1	1
22	20612031	Presser foot corner plate	1	1	1
23	20127016	Presser foot spring	0	0	1
24	20112042	Presser foot holder connection plate	1	1	0
25	206S20007	Screw	1	1	1
26	S02003	Screw	2	2	2
27	20327001	Presser foot lifting spring	1	1	1
28	20112045	Presser foot holder cover	1	1	1
29	20116001	Presser foot complete	1	0	0
	20116002	Presser foot complete	0	1	0
	20116003	Presser foot complete	0	0	1
	20116006	Presser foot complete	1	0	0
	20116007	Presser foot complete	0	0	1
	20516015	Presser foot complete	0	0	1
	20116004	Presser foot complete	1	0	0
	20116005	Presser foot complete	0	1	0
30	20312001	Presser foot lifting handle	1	1	1
31	20326001	Presser foot lifting annul	1	1	1
32	20312002	Presser foot lifting handle bracket	1	1	1
33	20103028	Presser bar bushing	1	1	1
34	20327002	Presser foot lifting spring	1	1	1
35	P03028	Pin	1	1	1
36	201S20004	Set screw	1	1	1
37	201S30020	Lifting handle screw	1	1	1
38	201S11005	Screw	3	3	3
39	201S12007	Crank set screw	1	1	1
40	S10005	Snap washer screw	3	3	3
41	201S14002	Screw	1	1	1
42	201S11016	Set plate screw	2	2	2
43	S01023	Screw	1	1	1
44	206S16005	Nut	1	1	1
45	201S11035	Screw	1	1	1
46	203S30002	Screw	1	1	1
47	203S12001	Screw	1	1	1
48	201S16003	Nut	1	1	1

6.15

Lubrication
Components

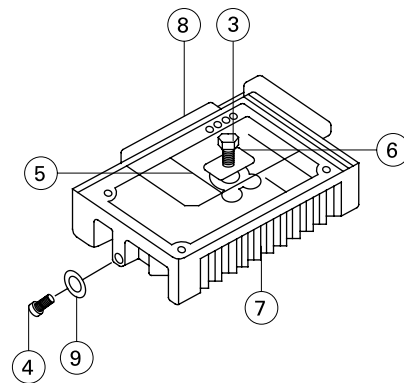
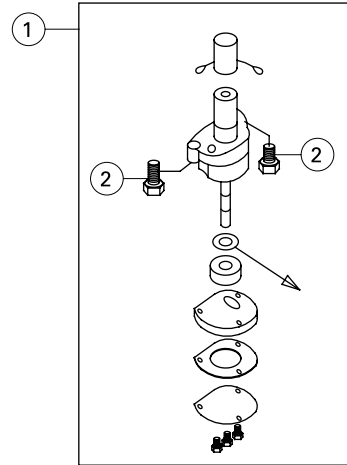
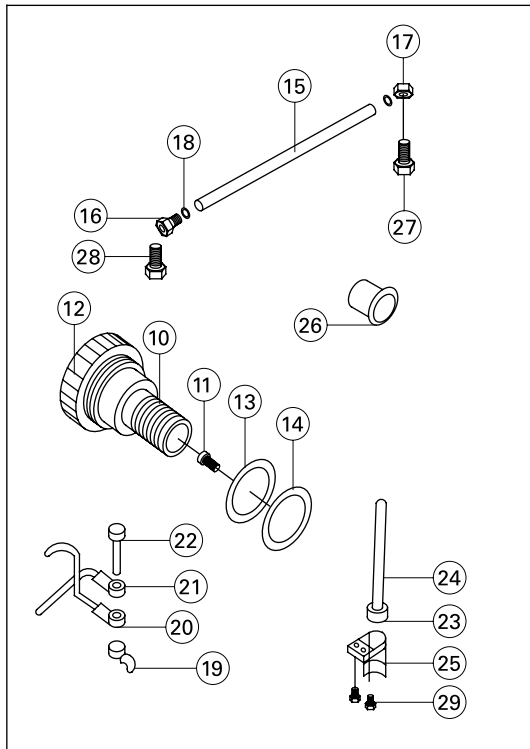

6.15

Lubrication Components

No.	Part No.	Description	Qty		
			3 thread	4 thread	5 thread
1	20120001	Oil pump complete	1	1	1
2	201S11025	Oil pump screw	2	2	2
3	201S11019	Oil pan magnet cover screw	1	1	1
4	201S11031	Oil pan screw	1	1	1
5	10131001	Oil pan magnet	1	1	1
6	20112050	Oil pan magnet cover	1	1	1
7	20101035	Oil pan	1	1	1
8	20122035	Oil pan washer	1	1	1
9	20122036	Oil seal	1	1	1
10	20136001	Oil filter	1	1	1
11	20121013	Oil filter joint	1	1	1
12	20101068	Oil filter cover	1	1	1
13	20322004	Oil filter cover seal ring	1	1	1
14	001015	Oil filter cover seal ring	1	1	1
15	2032100400	Tube	1	1	1
16	20136002	Oil tube joint I	1	1	1
17	20136003	Oil tube joint II	1	1	1
18	30129003	Oil tube shape ring	1	1	1
19	20301006	Lubricate bushing	1	1	1
20	20321002	Upper drain pipe	1	1	1
21	20321003	Lower drain pipe	1	1	1
22	203S30004	Screw	1	1	1
23	20311005	Oil show bracket	1	1	1
24	20311006	Oil show cleaner link	1	1	1
25	20312003	Oil show cleaner guard	1	1	1
26	20311008	Oil dial	1	1	1
27	203S30003	Screw	1	1	1
28	201S30004	Screw	1	1	1
29	201S11014	Screw	2	2	2

6.16

Feed Snap Components

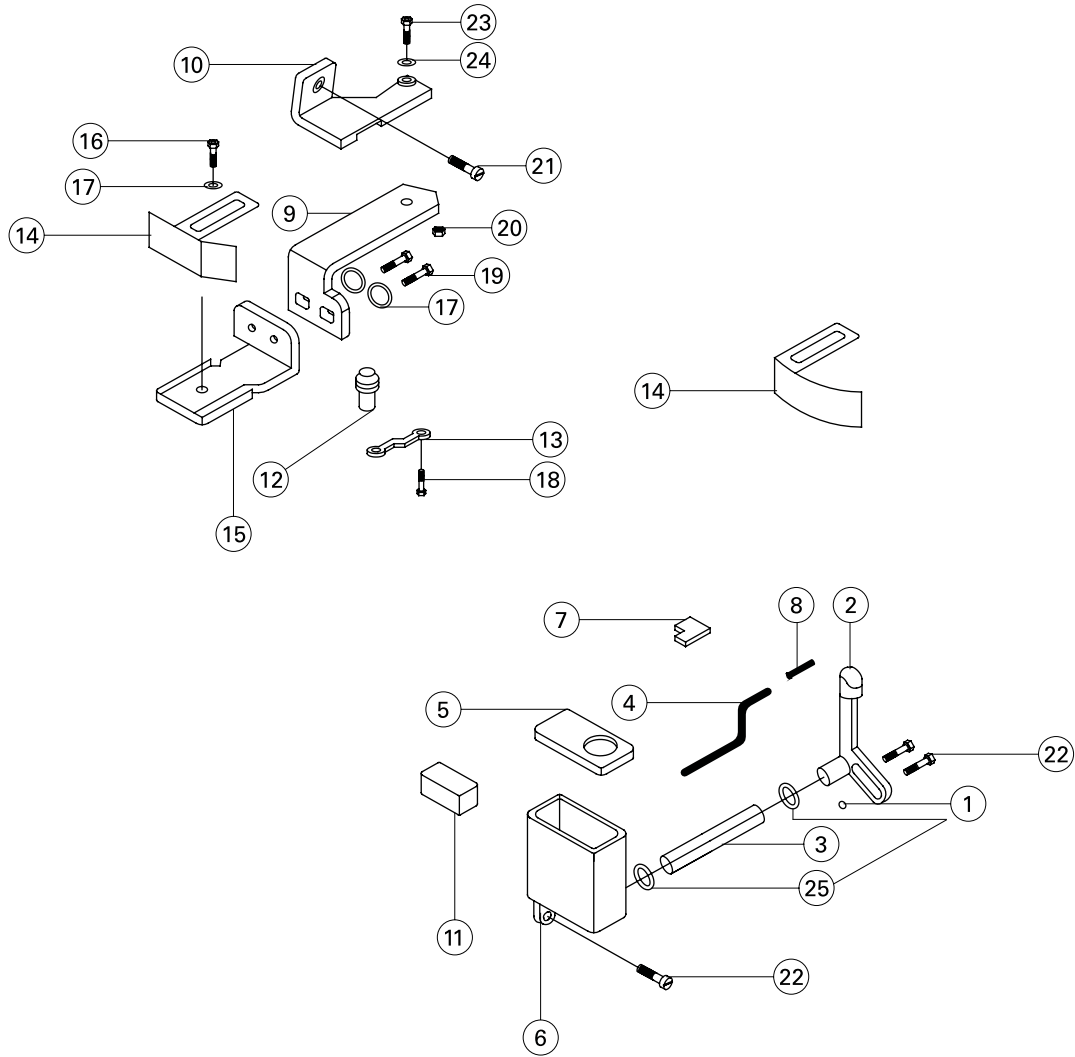

6.16

Feed Snap Components

No.	Part No.	Description	Qty		
			3 thread	4 thread	5 thread
1	20123012	Oil seal	1	1	1
2	20101037	Needle cooler	1	1	0
	20101038	Needle cooler	0	0	1
3	20121019	Oil tube	1	1	1
4	20123021	Oil wick	1	1	1
5	20111011	Silicon oil box cover (Lower)	1	1	1
6	20111012	Silicon oil box (Lower)	1	1	1
7	20123014	Oil felt	1	1	0
	20123015	Oil felt	0	0	1
8	20123021	Oil wick	1	1	1
9	20112051	Cloth guide holder	1	1	1
10	20112052	Hinge plate	1	1	1
11	20123017	Oil felt block	1	1	1
12	20126020	Hinge pin	1	1	1
13	20112053	Hinge spring	1	1	1
14	20112054	Snap plate	1	1	0
	20112055	Snap plate	0	0	1
	20112071	Snap plate	1	1	0
15	20112056	Snap plate bracket	1	1	1
16	201S11009	Screw	1	1	1
17	20128020	Washer	3	3	3
18	201S11011	Hinge spring screw	1	1	1
19	201S12001	Hinge screw	2	2	2
20	201S16003	Nut	1	1	1
21	201S11016	Screw	1	1	1
22	201S11018	Needle cooler screw	3	3	3
23	201S20002	Screw	1	1	1
24	20128027	Washer	1	1	1
25	20129002	Oil tube shape ring	2	2	2

6.17

Thread Spool Components

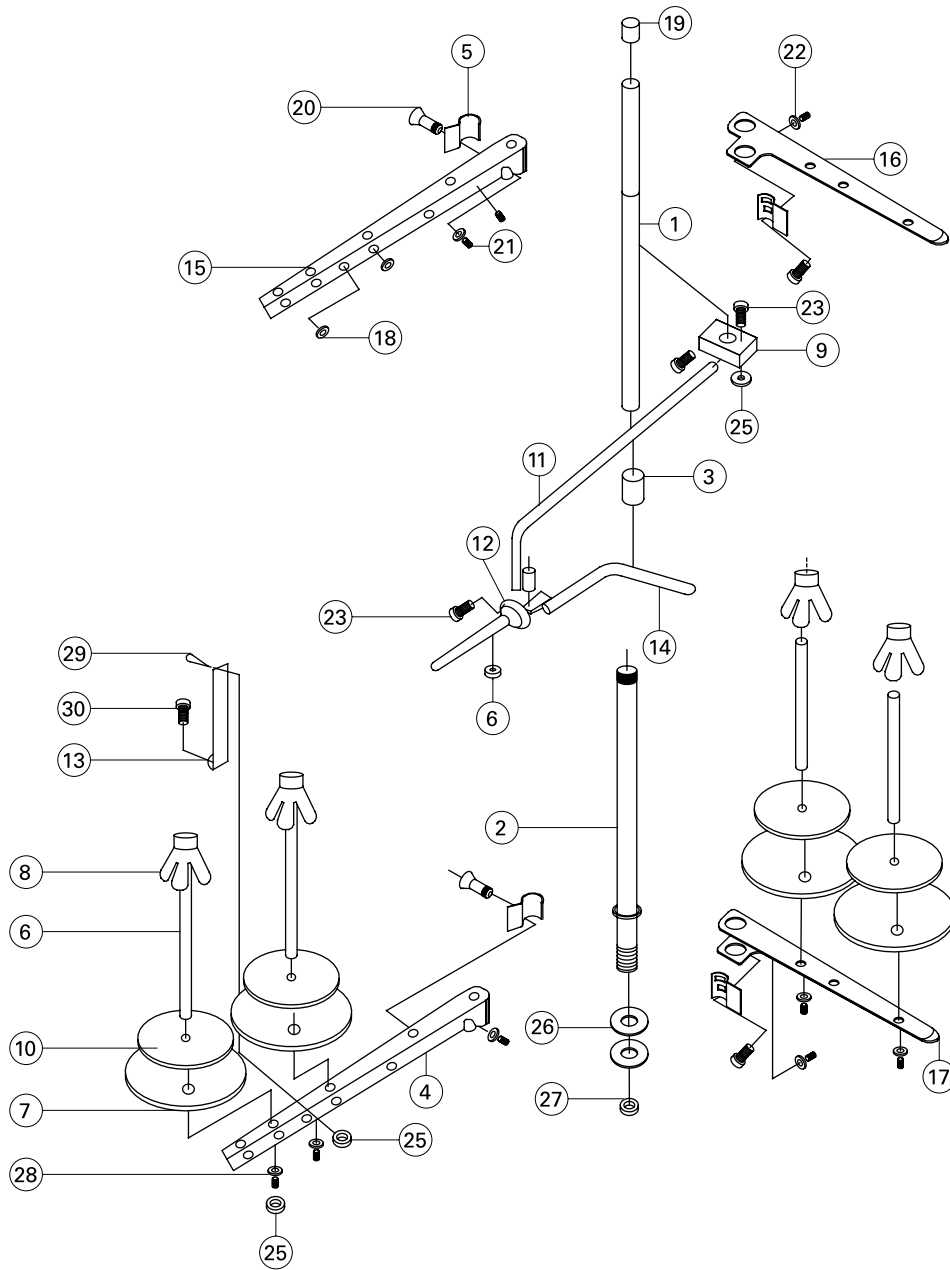

6.17

Thread Spool Components

No.	Part No.	Description	Qty		
			3 thread	4 thread	5 thread
1	20131001	Upper thread column	1	1	1
2	20131002	Lower thread column	1	1	1
3	20131003	Bushing	1	1	1
4	20131004	Thread spool tray bracket (lower)	1	0	1
5	20131005	Thread guide hook	2	4	4
6	20131006	Spool pin	3	4	5
7	20131007	Spool tray	3	4	5
8	20131008	Spool retainer	3	4	5
9	20131009	Clamp plate	1	1	1
10	20131010	Spool tray cushion	3	4	5
11	20131011	Thread guide connecting bar	1	1	1
12	20131012	Thread guide joint	1	1	1
14	20131014	Thread guide bar	1	1	1
15	20131015	Thread spool tray bracket (upper)	1	0	1
16	20131016	Thread spool tray bracket (upper)	0	2	1
17	20131017	Thread spool tray bracket (lower)	0	2	1
18	20131018	Thread guide hook	3	4	5
19	20131019	Rubber seal	1	1	1
20	20131020	Thread guide hook screw	2	4	4
21	201S16006	Thread guide hook nut	2	4	4
22	20128016	Thread guide washer	4	4	4
23	20131021	Clamp plate screw	3	3	3
25	201S16004	Nut	8	8	8
26	20128025	Lower washer	2	2	2
27	201S16005	Nut	1	1	1
28	20128018	Washer	4	4	4

6.18

Plate Row Material Components

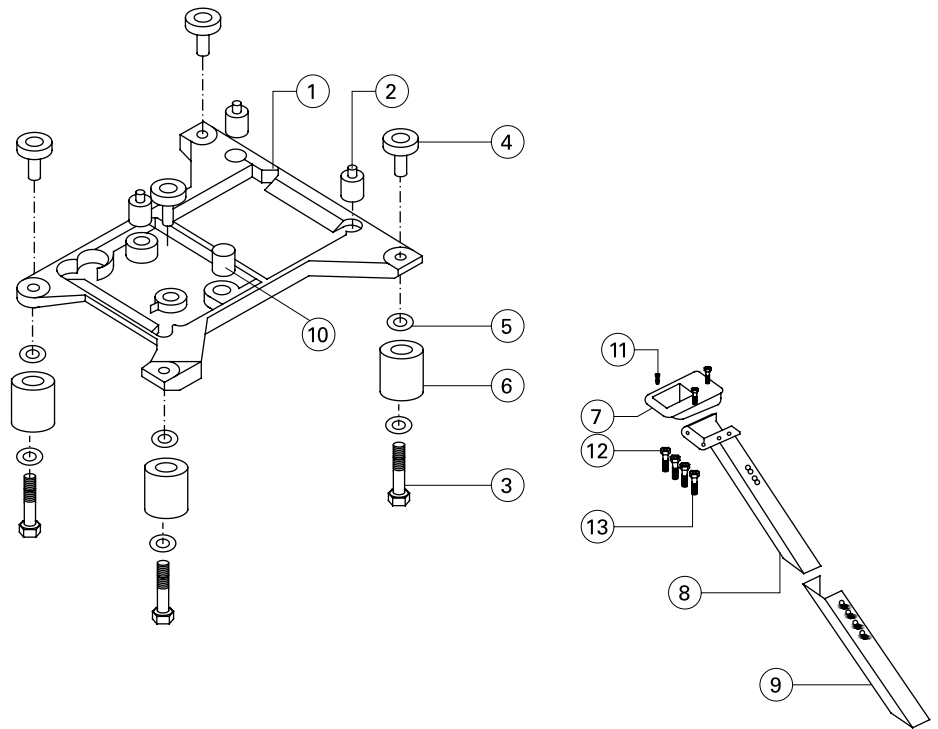

No.	Part No.	Description	Qty		
			3 thread	4 thread	5 thread
1	20131025	Machine support plate	1	1	1
2	20131026	Support shockproof cushion	3	3	3
3	20131027	Screw	4	4	4
4	20131028	Bolt	4	4	4
5	20131029	Washer	12	12	12
6	20131030	Bolt specer	12	12	12
7	20131031	Waste chute inlet	1	1	1
8	20131032	Waste chute (upper)	1	1	1
9	20131033	Waste chute (lower)	1	1	1
10	20131057	Cushion rubber	1	1	1
11	20131034	Screw	3	3	3
12	20128022	Washer	4	4	4
13	20131035	Screw	4	4	4

6.19

Accessories

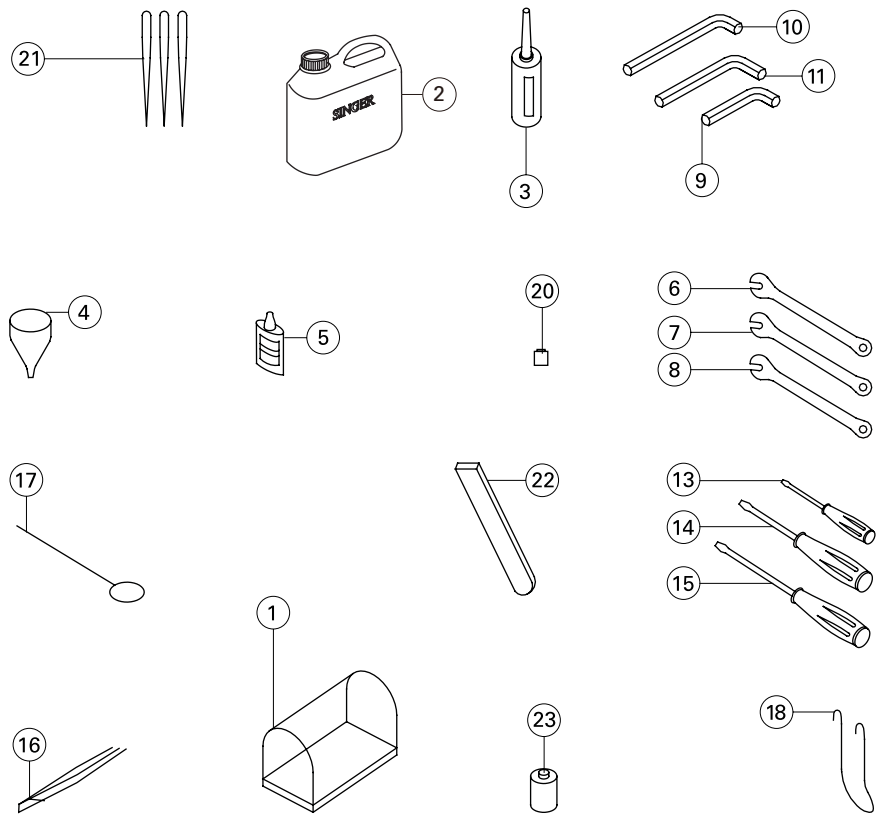

No.	Part No.	Description	Qty		
			3 thread	4 thread	5 thread
1	20131036	Dust cover	1	1	1
2	20131037	Oil can	1	1	1
3	20131038	Notes oil	1	1	1
4	20131039	Funnel	1	1	1
5	20131040	Oil can/50cc	1	1	1
6	20131041	Spanner	1	1	1
7	20131042	Spanner	1	1	1
8	20131043	Spanner	1	1	1
9	20131044	Inner-hexagon screw driver	1	1	1
10	20131045	Inner-hexagon screw driver	1	1	1
11	20131046	Inner-hexagon screw driver	1	1	1
13	20131048	Allen Key Driver	2	2	2
14	20131049	Screw driver	1	1	1
15	20131050	Screw driver	1	1	1
16	20131051	Tweezers	1	1	1
17	20131052	Threader	0	0	1
18	20131054	Presser foot base chain	1	1	1
20	201S14001	Thumb screw	4	4	4
21	20117001	Needle	3	3	3
22	20119002	Lower knife	1	1	1
	20119006	Lower knife	0	0	1
23	20136001	Oil filter	1	1	1
24	xxxxxxx	Belt	1	1	1

Gauge Parts List

Machine Model	Needle Gauge		Needle Plate	Feed Dog Complete	Presser Foot Complete	Upper Looper
	Needle Gauge	Overedge Width				
321C-132M-015	0	1,5	20115006	2011401800	20116006	20117007
321C-131M-04	0	4	20115001	2011401700	20116001	20117007
321C-133M-04/TF	0	4	20115004	2011402100	20116004	20117007
321C-134M-04	0	4	20115001	2011401700	20116004	20117007
321C-241M-24	2	4	20115002	2011401700	20116002	20117007
321C-241M-25	2	5	20115010	2011402200	20116008	20117007
321C-243M-24/TF	2	4	20115005	2011402100	20116005	20117007
321C-244M-24	2	4	20115002	2011401700	20116002	20117007
321C-251M-35	3	5	20115003	2011401900	20116003	20117007
321C-251M-55	5	5	20115008	2011401900	20116007	20117007
321C-251H-56	5	6	20115007	2011402000	20116015	20117007

Machine Model	Needle Cramp	Washer	Crank	Lower Looper Crank	Needle
321C-132M-015	20134002	20128006	20104003	20104009	6120-06 65/9
321C-131M-04	20134002	20128006	20104003	20104009	6120-06 75/11
321C-133M-04/TF	20134002	20128006	20104003	20104009	6120-06 75/11
321C-134M-04	20134002	20128006	20104003	20104009	6120-06 75/11
321C-241M-24	20134001	20128005	20104002	20104009	6120-06 75/11
321C-241M-25	20134001	20128035	20104002	20104009	6120-06 75/11
321C-243M-24/TF	20134001	20128005	20104002	20104009	6120-06 75/11
321C-244M-24	20134001	20128005	20104002	20104010	6120-06 75/11
321C-251M-35	20134003	20128005	20104002	20104010	6120-06 90/14
321C-251M-55	20134004	20128005	20104002	20104010	6120-06 90/14
321C-251H-56	20134004	20128005	20104002	20104010	6120-06 132/21

From the library of: Diamond Needle Corp

